

PLASMA CUTTING TORCHES AND CONSUMABLES

The new series of Plasma Cutting Torches
with and without High Frequency Start



The new series of Plasma Cutting Torches with High Frequency Start

TBi PLC 60	Suitable for: CEBORA® P50 _____	page 4
TBi PLC 70	Suitable for: CEBORA® P70 _____	page 6
TBi PLC 90	Suitable for: CEBORA® CP90 - CP91 _____	page 8
TBi PLC 120	Suitable for: LINCOLN® T100 _____	page 10
TBi PLC 150	Suitable for: CEBORA® P150 - CP160 _____	page 12
TBi TTP 81	Suitable for: TRAFIMET® A80 - Ergocut A81 _____	page 14
TBi TTP 101	Suitable for: TRAFIMET® A90 - Ergocut 101 _____	page 16
TBi TTP 141	Suitable for: TRAFIMET® A140 - Ergocut 141 _____	page 18
TBi TTP 151	Suitable for: TRAFIMET® R145 - Ergocut A151 _____	page 20
TBi PLC 250W	replacement for CEBORA® CB 200 _____	page 22
	but with <u>different</u> consumable parts than Cebora® CB 200	
TBi PLC AUT	replacement for CEBORA® CB 200 _____	page 24
250W - 250W-2	but with <u>different</u> consumable parts than Cebora® CB 200	

The new series of Plasma Cutting Torches without High Frequency Start

TBi RPT 100HY	Suitable for Hypertherm® Plasma Systems PowerMax® 1000/1250/1650 _____	page28
TBi RPT AUT100 HY	Suitable for Hypertherm® Plasma Systems PowerMax® 1000/1250/1650 _____	page30

Suitable for: CEBORA® P50

Max Current : 50 Amps
 Duty Cycle : 50 Amps- 60%
 Gas: Air
 Gas Pressure: 4.5-5.0 bar (70 psi)
 Gas Flow: 120 ltr.p.m (250 scfh)
 Post Flow Time: 90 sec. recommended
 Pilot : Electrode to tip
 Ignition: HF

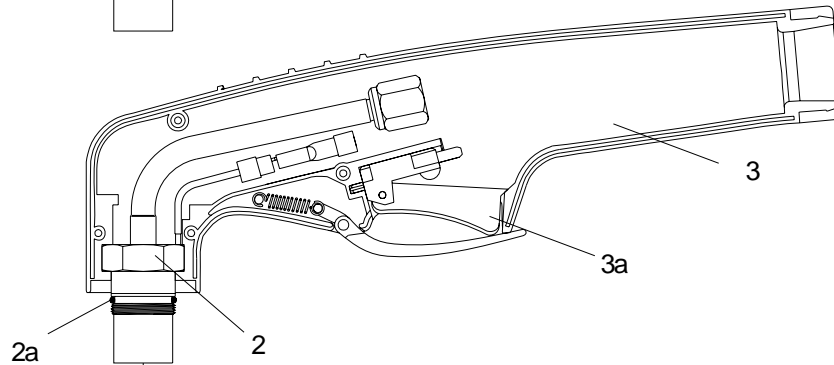
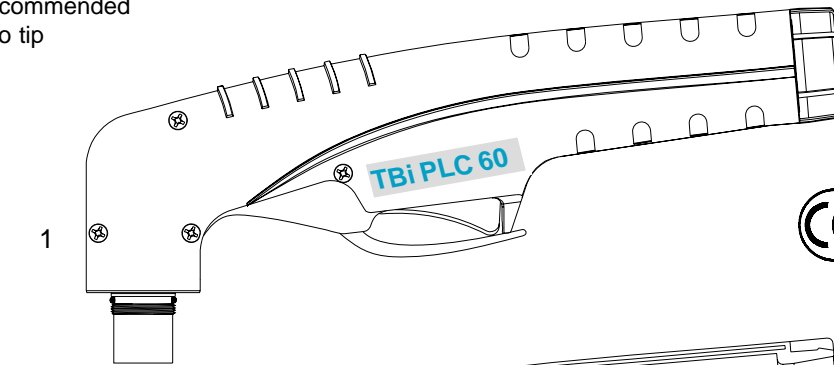

- Higher performances
- Faster Speed
- Cleaner cut

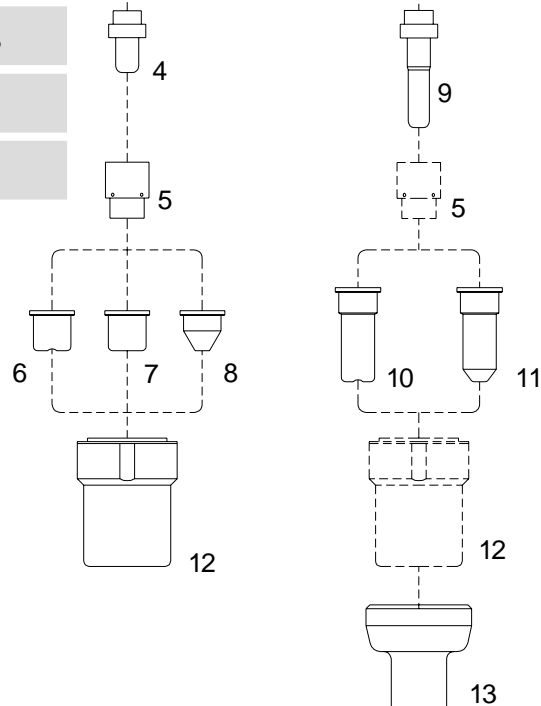

TBi Industries GmbH is in no way affiliated with CEBORA®. The parts advertised for sale are not genuine CEBORA® parts, but are parts made for and by TBi Industries GmbH. Reference to CEBORA® machine, torches and numbers are for your convenience only. We reserve the right to substitute genuine CEBORA® parts in place of TBi Industries GmbH parts.

Replacement torch and parts suitable for: CEBORA® P50

<u>Pos.</u>	<u>Part Number</u>	<u>Ref.-No.</u>	<u>Description</u>	<u>Prod.-Gr.</u>	<u>PU</u>	<u>List price</u>
			Torches cpl. with rubber cover (RC)			
	443P060406		Hand torch TBi PLC 60-6m-G1/8" AG-RC	30101	1	228,00•
	443P060412		Hand torch TBi PLC 60-12m-G1/8" AG-RC	30101	1	304,00•
	443P060106		Hand torch TBi PLC 60-6m-Central connector-RC	30101	1	275,00•
	443P060112		Hand torch TBi PLC 60-12m-Central connector-RC	30101	1	351,00•
	443P060206		Hand torch TBi PLC 60-6m-G1/4" IG-RC	30101	1	208,00•
	443P060212		Hand torch TBi PLC 60-12m-G1/4" IG-RC	30101	1	304,00•
			Torch head, handle and consumables			
1	443P060001		Torch head TBi PLC 60 complete with handle	30112	1	97,00•
2	• 443P060002		Torch head TBi PLC 60	30112	1	79,00•
2a	• 365P120078		O -Ring	30115	20	0,30•
3	• 380P200001		Handgrip with switch	30115	1	16,00•
3a	• 385P021016		Switch	10175	10	3,00•
4	441P101010	1521- Zr	Electrode - Zr.	30110	10	1,80•
	• 441P101011	1521- Hf	Electrode - Hf.	30110	10	2,20•
5	• 441P102001		Swirl ring	30110	2	13,20•
6	• 441P102002	1304	Tip ø 1.0	30110	10	1,40•
	441P102010	1396	Tip long life ø 1.0	30110	10	1,50•
	441P102011		Tip long life ø 1.1	30110	10	1,50•
7	441P884410		Flat tip ø 1.0.	30110	10	2,00•
8	441P102012	1305	Conical tip ø 1.0 (Lo - Amp.)	30110	10	1,80•
9	441P101005	1518- Zr	Extended electrode - Zr.	30110	10	2,40•
	441P101006	1518- Hf	Extended electrode - Hf.	30110	10	2,80•
10	441P102013	1370	Extended tip, ø 1.0 **	30110	10	2,10•
	441P070017	1395	Extended tip, long life ø 1.0 **	30110	10	2,10•
	441P102014		Extended tip, long life ø 1.1 **	30110	10	2,20•
11	441P102015	1306	Extended conical tip ø 1.0 (Lo - Amp.)	30110	10	2,30•
12	• 441P101020	5.710.121	Nozzle retaining cap	30109	10	9,30•
13	441P102020		Shield cup, hand (for extended tips**)	30109	10	9,50•
			Accessories			
N/S	441P101990	166	Circle cutting attachment	30118	1	105,00•
N/S	441P101900	154	Cutting guide	30118	1	43,00•

• = standard equipment

Suitable for: CEBORA® P70

Max Current : 70 Amps
 Duty Cycle: 70 Amps- 60%
 Gas: Air
 Gas Pressure: 4.5-5.0 bar (70 psi)
 Gas Flow: 130 ltr.p.m (275 scfh)
 Post Flow Time: 90 sec. recommended
 Pilot : Electrode to Tip
 Ignition: HF

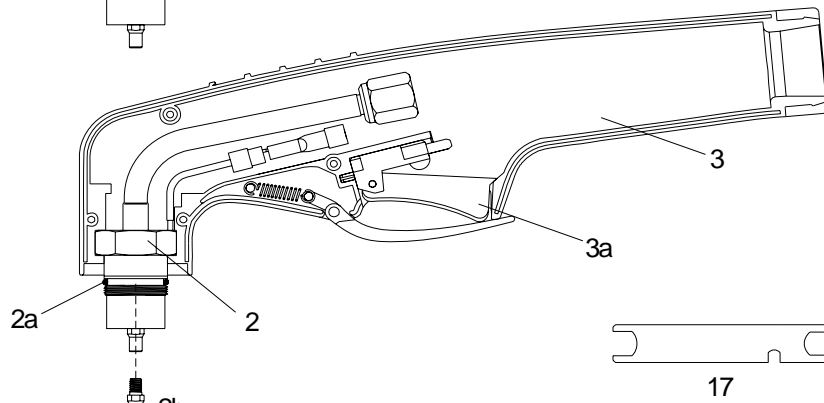
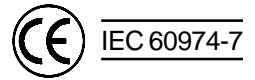
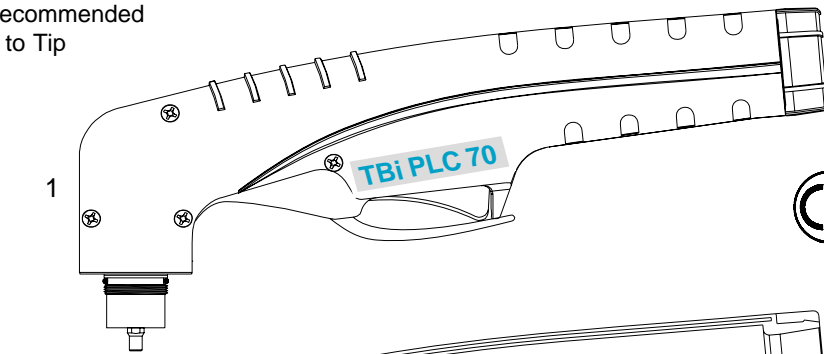

- Higher performances
- Faster Speed
- Cleaner cut

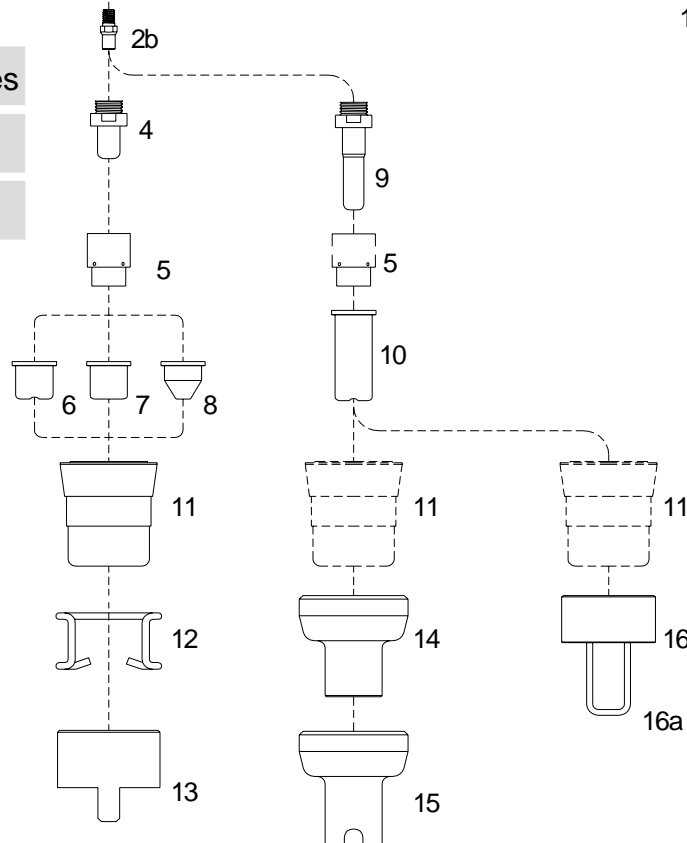

TBi Industries GmbH is in no way affiliated with CEBORA®. The parts advertised for sale are not genuine CEBORA® parts, but are parts made for and by TBi Industries GmbH. Reference to CEBORA® machine, torches and numbers are for your convenience only. We reserve the right to substitute genuine CEBORA® parts in place of TBi Industries GmbH parts.

Replacement torch and parts suitable for: CEBORA® P70

<u>Pos.</u>	<u>Part Number</u>	<u>Ref.-No.</u>	<u>Description</u>	<u>Prod.-Gr.</u>	<u>PU</u>	<u>List price</u>
			Torches cpl. with rubber cover			
	443P070406	1564	Hand torch TBI PL 70-6m-G1/8" AG-RC	30101	1	268,00 •
	443P070106	1573	Hand torch TBI PL 70-6m-Central connector-RC	30101	1	322,00 •
	443P070212		Hand torch TBI PL 70-12m-G1/8" AG-RC	30101	1	322,00 •
	443P070412	1573.20	Hand torch TBI PL 70-12m-Central connector-RC	30101	1	365,00 •
	443P070206		Hand torch TBI PL 70-6m-G1/4" IG-RC	30101	1	268,00 •
	443P070212		Hand torch TBI PL 70-12m-G1/4" IG-RC	30101	1	322,00 •
			Torch head, handle and consumables			
1	443P070001		Torch head TBI PL 70 complete with handle	30112	1	103,00 •
2	• 443P070002		Torch head TBI PL 70	30112	1	86,00 •
2a	• 365P120178		O -Ring	30115	20	0,90 •
2b	• 441P070003	3.065204	Diffusor	30110	2	3,80 •
3	• 380P200001		Handgrip with switch	30115	1	16,00 •
3a	• 385P021016		Switch	10175	10	3,00 •
4	• 441P070010	1402	Electrode	30110	10	2,30 •
5	• 441P102001		Swirl ring	30110	2	13,20 •
6	441P070004	1309	Tip ø 0.9 - 35A	30110	10	1,50 •
	441P102010	1396	Tip long life ø 1.0 - 50A	30110	10	1,50 •
	441P102011		Tip long life ø 1.1 - 60A	30110	10	1,50 •
	• 441P070015		Tip long life ø 1.2 - 70A	30110	10	1,50 •
	441P070032	1308	Tip ø 1.2 - 70A	30110	10	1,50 •
7	441P884410		Flat tip ø 1.0	30110	10	2,00 •
	441P070033		Flat tip ø 1.2	30110	10	2,00 •
8	441P102012	1305	Conical tip ø 1.0 (Lo - AMP)	30110	10	1,80 •
	441P070034		Conical tip ø 1.2	30110	10	1,80 •
9	441P070011	1368	Extended electrode	30110	10	2,90 •
10	441P070005	1366	Extended tip ø 0.9 - 35A *	30110	10	2,10 •
	441P070017	1395	Extended tip long life ø 1.0 - 50A *	30110	10	2,10 •
	441P102014		Extended tip long life ø 1.1 - 60A **	30110	10	2,20 •
	441P070018		Extended tip long life ø 1.2 - 70A **	30110	10	2,10 •
11	• 441P070009	5.710.171	Nozzle retaining cap	30109	10	9,20 •
12	441P070020	1394	Spacer spring	30110	10	1,80 •
13	441P070021	1405	Double pointed spacer	30110	10	10,90 •
14	441P070038		Shield cup, hand (for extended tips*)	30109	10	9,80 •
15	441P070039		Spacer for cont. cutting, hand (for extended tips**)	30109	10	12,00 •
16	441P070040		Spacer complete with springs	30110	10	13,00 •
16a	441P070041		Spare springs (20 pcs)	30110	10	0,90 •
17	• 441P020310	3.045.012	Wrench for electrode	30115	10	3,10 •
			Accessories			
N/S	441P070900	166-70	Circle cutting attachment	30118	1	105,00 •
N/S	441P070901	154-70	Cutting guide	30118	10	43,00 •

Suitable for: CEBORA® CP90 - CP 91

Max Current : 90 Amps
 Duty Cycle: 90 Amps- 60%
 Gas: Air
 Gas Pressure: 4.5-5.0 bar (70 psi)
 Gas Flow: 160 ltr.p.m (340 scfh)
 Post Flow Time: 90 sec. recommended
 Pilot : Electrode to Tip
 Ignition: HF

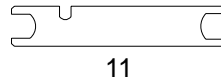
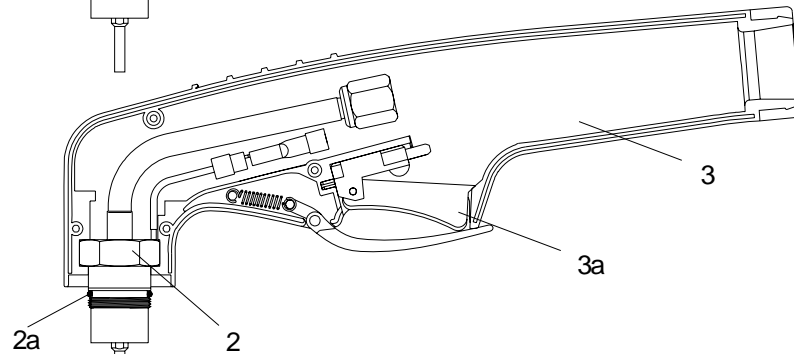
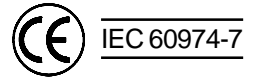
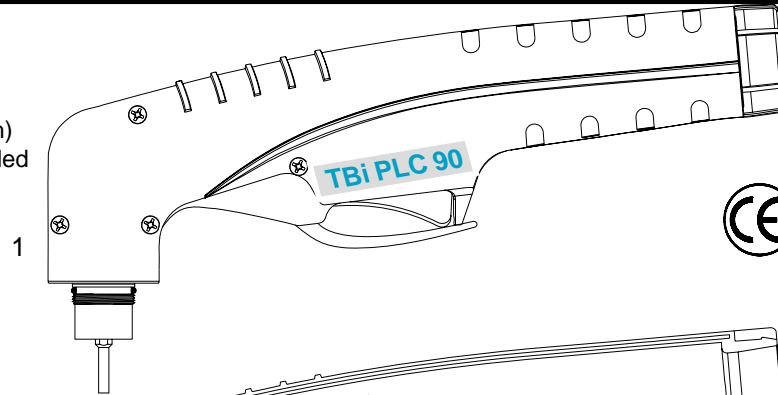

- Higher performances
- Faster Speed
- Cleaner cut

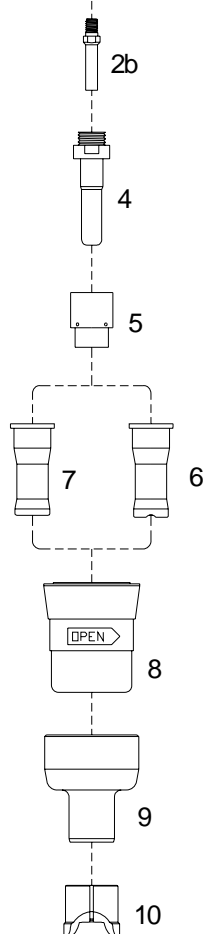

TBi Industries GmbH is in no way affiliated with CEBORA®. The parts advertised for sale are not genuine CEBORA® parts, but are parts made for and by TBi Industries GmbH. Reference to CEBORA® machine, torches and numbers are for your convenience only. We reserve the right to substitute genuine CEBORA® parts in place of TBi Industries GmbH parts.

Replacement torch and parts suitable for: CEBORA® CP90 - CP 91

<u>Pos.</u>	<u>PartNumber</u>	<u>Ref.-No.</u>	<u>Description</u>	<u>Prod.-Gr.</u>	<u>PU</u>	<u>Listprice</u>
			Torches cpl. with rubber cover (RC)			
	443P090406		Hand torch TBI PL 90-6m-G1/8" AG-RC	30101	1	303,00 •
	443P090106		Hand torch TBI PL 90-6m-Central connector-RC	30101	1	358,00 •
	443P090412		Hand torch TBI PL 90-12m-G1/8" AG-RC	30101	1	427,00 •
	443P090112		Hand torch TBI PL 90-12m-Central connector-RC	30101	1	482,00 •
	443P090206		Hand torch TBI PL 90-6m-G1/4" IG-RC	30101	1	303,00 •
	443P090212		Hand torch TBI PL 90-12m-G1/4" IG-RC	30101	1	427,00 •
			Torch head, handle and consumables			
1	443P090001		Torch Head TBI PL 90 complete with handle	30112	1	108,00 •
2	• 443P090002		Torch Head TBI PL 90	30112	1	90,00 •
2a	• 365P120178	3.160.067	O -Ring	30115	20	0,90 •
2b	• 441P091003		Diffusor	30110	2	8,80 •
3	• 380P200001		Handgrip with switch	30115	1	16,00 •
3a	• 385P021016		Switch	10175	10	3,00 •
4	• 441P070011	1368	Electrode	30110	10	2,90 •
5	441P102001		Swirl ring	30110	2	13,20 •
6	441P091004		Tip long life - 20-40A (use with pos. 9* only)	30110	10	3,00 •
7	441P091005		Tip long life ø 1.2 - 50-70A (use with pos. 9-10** only)	30110	10	3,00 •
	• 441P091006		Tip long life ø 1.3 - 70-90A (use with pos. 9-10** only)	30110	10	3,00 •
8	• 441P091007		Nozzle retaining cap	30109	10	11,40 •
9	• 441P091008		Shield cup, hand * / **	30109	10	9,60 •
10	• 441P091009		Spacer for contact cutting, hand **	30109	10	15,30 •
11	• 441P020310	3.045.012	Wrench for electrode	30115	10	3,10 •
			Accessories			
N/S	441P091900	163	Circle cutting attachment	30118	1	121,00 •
N/S	441P091901	153	Cutting guide	30118	10	57,00 •

• = standard equipment

Suitable for: LINCOLN® T100

Max Current : 100 Amps
 Duty Cycle: 100 Amps - 60%
 Gas: Air
 Gas Pressure: 4.5-5.0 bar (70 psi)
 Gas Flow: 180 ltr.p.m (360 scfh)
 Post Flow Time: 90 sec. recommended
 Pilot : Electrode to Tip
 Ignition: HF

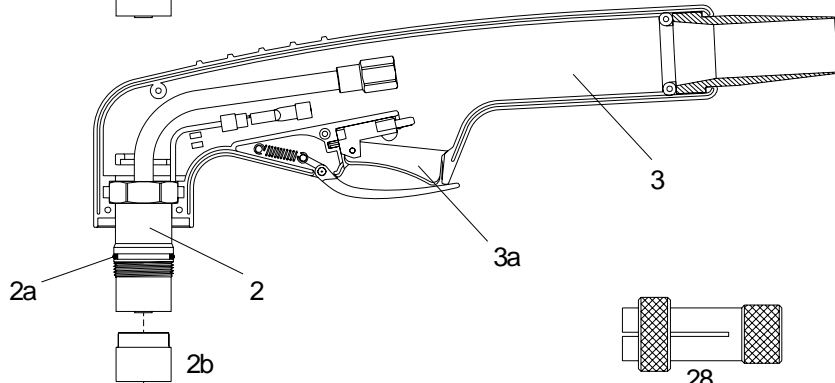
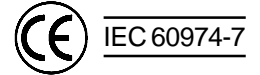
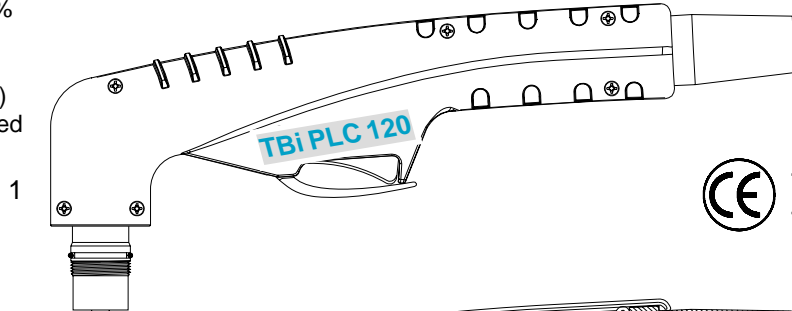

- Higher performances
- Faster Speed
- Cleaner cut

TBi Industries GmbH is in no way affiliated with Lincoln®. The parts advertised for sale are not genuine Lincoln® parts, but are parts made for and by TBi Industries GmbH. Reference to Lincoln® machine, torches and numbers are for your convenience only. We reserve the right to substitute genuine Lincoln® parts in place of TBi Industries GmbH parts.

Replacement torch and parts suitable for: LINCOLN® T100

<u>Pos.</u>	<u>PartNumber</u>	<u>Ref.-No.</u>	<u>Description</u>	<u>Prod.-Gr.</u>	<u>PU</u>	<u>List price</u>
	443P120106		Torches cpl. with rubber cover Hand torch TBI PL 120-6m-Central connector-RC	30101	1	383,00 •
	443P120112		Hand torch TBI PL 120-12m-Central connector-RC	30101	1	507,00 •
			Torch head, handle and consumables			
1	443P120001		Torch Head TBI PL 120 complete with Handle	30112	1	158,00 •
2	• 443P120002		Torch Head TBI PL 120	30112	1	129,00 •
2a	• 365P170178	W0300121	O -Ring	30115	20	0,50 •
2b	• 441P090003		Front insulator	30110	1	45,00 •
2c	• 441P020300	W0300122	Diffusor	30110	2	3,20 •
3	• 380P200002		Handgrip with microswitch	30115	1	16,00 •
3a	• 385P021016	W0300103	Switch	10175	10	3,00 •
4	• 446P101010	W0300123	Electrode	30110	10	2,90 •
5	• 446P102001	W0300124	Swirl ring	30110	2	12,00 •
6	446P102010		Tip long life ø 1,10 (replaces W0300125)	30110	10	2,50 •
	446P102011	W0300174	Tip long life ø 1,35 (replaces W0300126)	30110	10	2,50 •
	• 446P102012	W0300175	Tip long life ø 1,60 (replaces W0300127)	30110	10	2,50 •
	446P102014	W0300128	Gouging tip ø 2,4	30110	10	2,50 •
7	446P102030	W0300135	Contact tip ø 1,35	30110	10	2,70 •
	446P102031	W0300137	Contact tip ø 1,6	30110	10	2,70 •
8	441P020019		Extended diffusor	30110	10	11,30 •
9	446P101015	W0300133	Extended electrode	30110	10	5,30 •
10	446P102020	W0300134	Extended tip (for contact cutting max. 50AMP)	30110	10	7,30 •
11	446P102021	W0300178	Extended tip ø 1,35 - 90A - (for pos. 20; 22; 23)	30110	10	6,20 •
	446P102022	W0300179	Extended tip ø 1,6 - 120A - (for pos. 20; 22; 23)	30110	10	6,20 •
12	• 441P090009	W0300129	Nozzle retaining cap	30109	10	25,70 •
13	441P090010	W0300138	Contact nozzle retaining cap	30109	10	46,20 •
14	446P102063	W0300244	Spring holder protection nut	30110	10	8,70 •
15	446P102064	W0300245	Spacer spring for code 446P102063	30110	10	2,00 •
16	446P102068		Gouging spacer	30109	10	10,10 •
17	446P102060	W0300180	Spacer for contact cutting, hand	30109	10	10,90 •
18	446P102041		Spacer for contact cutting, hand	30109	10	14,40 •
19	446P102065	W0300182	Shield cup, hand (max. 50AMP)	30110	10	10,60 •
20	446P102066	W0300183	Spacer for contact cutting, hand	30110	10	15,90 •
21	446P102070		Spacer for extended tips, high AMP	30109	10	15,90 •
22	446P102067	W0300184	Locking nut	30110	10	4,90 •
23	446P102044	W0300187	Spacer complete with springs	30110	10	14,70 •
23a	446P102045	W0300188	Spare springs (20 pcs)	30110	10	0,90 •
24	• 441P020009	W0300130	Spacer spring	30110	10	1,90 •
25	441P010005	W0300131	Double pointed spacer	30110	10	12,90 •
26	441P020301	W0300177	Crown spacer	30110	6	13,10 •
27	446P102051	W0300132	Gouging spacer	30109	6	9,90 •
28	441P010303	W0300142	Extractor for swirl ring	30115	10	12,30 •
29	• 441P020310	W0300119	Wrench for electrode	30115	10	3,10 •
			Accessories			
N/S	446P101990		Circle cutting attachment	30118	1	112,00 •
N/S	441P101900		Cutting guide	30118	1	43,00 •

• = standard equipment

Suitable for: CEBORA® P150 - CP160

Max Current: 150 Amps
 Duty Cycle: 150 Amps - 60%
 Gas: Air
 Gas Pressure: 4.5-5.0 bar (70 psi)
 Gas Flow: 220 ltr.p.m (470 scfh)
 Post Flow Time: 90 sec. recommended
 Pilot: Electrode to Tip
 Ignition: HF

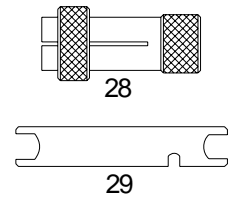
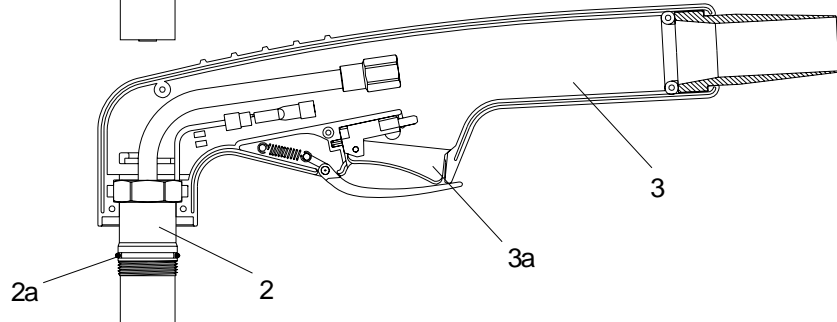
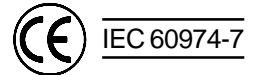
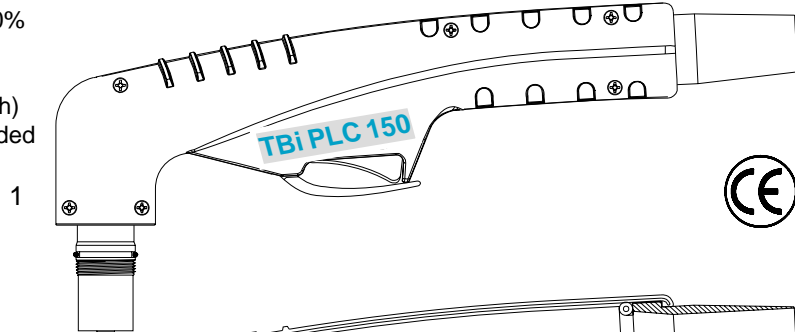

- Higher performances
- Faster Speed
- Cleaner cut

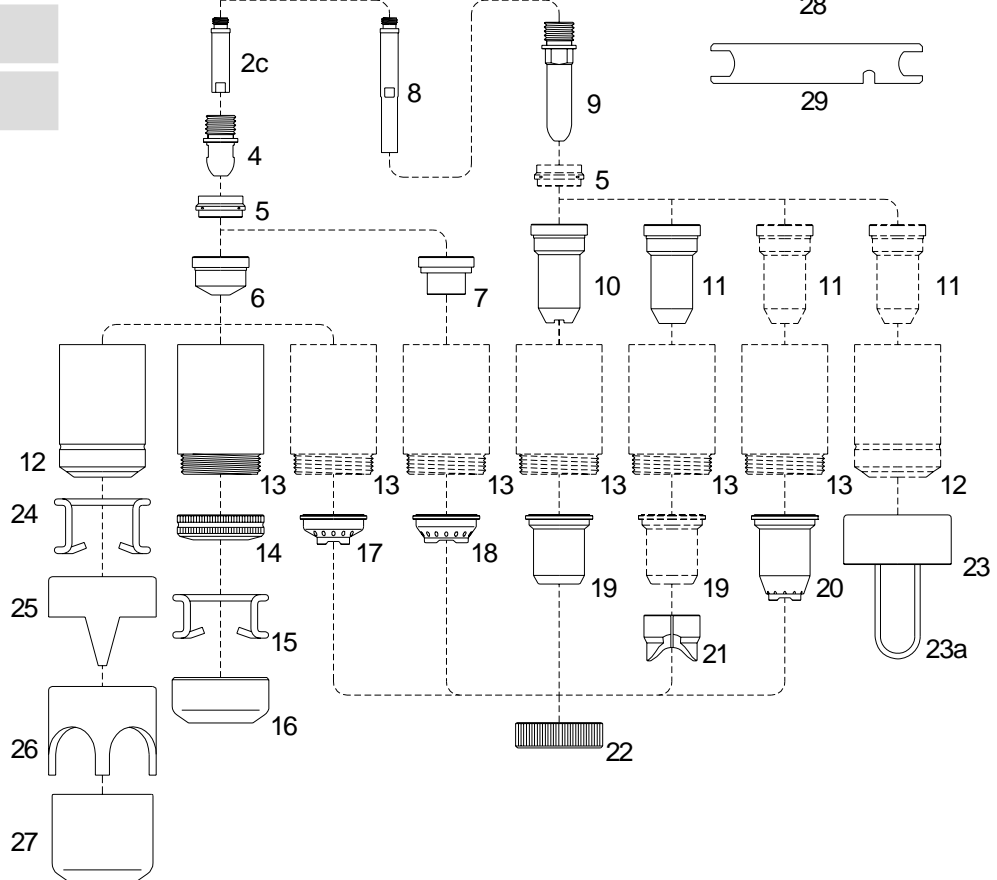

TBi Industries GmbH is in no way affiliated with CEBORA®. The parts advertised for sale are not genuine CEBORA® parts, but are parts made for and by TBi Industries GmbH. Reference to CEBORA® machine, torches and numbers are for your convenience only. We reserve the right to substitute genuine CEBORA® parts in place of TBi Industries GmbH parts.

Replacement torch and parts suitable for: CEBORA® P150 - CP 160

<u>Pos.</u>	<u>PartNumber</u>	<u>Ref.-No.</u>	<u>Description</u>	<u>Prod.-Gr.</u>	<u>PU</u>	<u>List price</u>
			Torches cpl. with rubber cover (RC)			
	443P150106		Hand torch TBI PL 150-6m-Central connector-RC	30101	1	386,00 •
	443P150112		Hand torch TBI PL 150-12m-Central connector-RC	30101	1	516,00 •
	443P160106		Hand Torch CP-160 -6m-Central Connector-RC	30101	1	395,00 •
	443P160112		Hand Torch CP-160 -12m-Central Connector-RC	30101	1	525,00 •
			Torch head, handle and consumables			
1	443P150001		Torch Head TBI PL 150 complete with Handle	30112	1	153,00 •
2	• 443P150002		Torch Head TBI PL 150	30112	1	135,00 •
2a	• 365P170178	1398	O -Ring	30115	20	0,50 •
2b	• 446P102003		Front insulator	30110	2	46,90 •
2c	• 446P102002	1378	Diffusor	30110	2	3,20 •
3	• 380P200002		Handgrip with microswitch	30115	1	16,00 •
3a	• 385P021016		Switch	10175	10	3,00 •
4	• 446P101010	1376	Electrode	30110	10	2,90 •
5	• 446P102001	1377	Swirl ring	30110	2	12,00 •
6	446P102010	1371	Tip long life ø 1,10	30110	10	2,50 •
	446P102011	1372	Tip long life ø 1,35	30110	10	2,50 •
	446P102012	1373	Tip long life ø 1,60	30110	10	2,50 •
	• 446P102013	1374	Tip long life ø 1,80	30110	10	2,50 •
	446P102014	1375	Gouging tip ø 3.0	30110	10	2,50 •
7	446P102030		Contact tip ø 1,35	30110	10	2,70 •
	446P102031		Contact tip ø 1,6	30110	10	2,70 •
	446P102032		Contact tip ø 1,8	30110	10	2,70 •
8	446P102004		Extended diffusor	30110	2	11,30 •
9	446P101015	1517	Extended electrode	30110	10	5,30 •
10	446P102020	1369	Extended tip (for contact cutting max. 50AMP)	30110	10	7,30 •
11	446P102021		Extended tip ø 1,35 - 90A - (for pos. 20, 22 + 23)	30110	10	6,20 •
	446P102022		Extended tip ø 1,6 - 120A - (for pos. 20, 22 + 23)	30110	10	6,20 •
	446P102023		Extended tip ø 1,8 - 150A - (for pos. 20, 22 + 23)	30110	10	6,20 •
12	• 446P101020	1389	Nozzle retaining cap	30109	6	27,70 •
13	446P102040		Contact nozzle retaining cap	30109	6	49,40 •
	446P102043		Contact nozzle retaining cap, maximum life	30109	6	66,10 •
14	446P102063		Spring holder protection nut	30110	10	8,70 •
15	446P102064		Spacer spring for code 446P102063	30110	10	2,00 •
16	446P102068		Gouging spacer	30109	10	10,10 •
17	446P102060		Spacer for contact cutting, hand	30109	10	10,90 •
18	446P102041		Spacer for contact cutting, hand	30109	10	14,40 •
19	446P102065		Shield cup, hand (max. 50AMP)	30110	10	10,60 •
20	446P102066		Spacer for contact cutting, hand	30110	10	15,90 •
21	446P102070		Spacer for extended tips, high AMP	30109	10	15,90 •
22	446P102067		Locking nut	30110	10	4,90 •
23	446P102044		Spacer complete with springs	30110	10	14,70 •
23a	446P102045		Spare springs (20 pcs)	30110	10	0,90 •
24	• 441P020009	1386	Spacer spring	30110	10	1,90 •
25	441P010005	1408	Double pointed spacer	30110	10	12,90 •
26	441P020301		Crown spacer	30110	6	13,10 •
27	446P102051	1406	Gouging spacer	30109	6	9,90 •
28	441P010303	1509	Extractor for swirl ring	30115	10	12,30 •
29	• 441P020310	3.045.010	Wrench for electrode	30115	10	3,10 •
			Accessories			
N/S	446P101990	169	Circle cutting attachment	30118	1	112,00 •
N/S	446P101900	155	Cutting guide	30118	1	47,00 •

• = standard equipment

Suitable for: TRAFIMET® A80 - Ergocut A81

Max Current : 80 Amps
 Duty Cycle: 80 Amps- 60%
 Gas: Air
 Gas Pressure: 4.5-5.0 bar (70 psi)
 Gas Flow: 160 ltr.p.m. (340 scfh)
 Post Flow Time: 90 sec. recommended
 Pilot : Electrode to Tip
 Ignition: HF

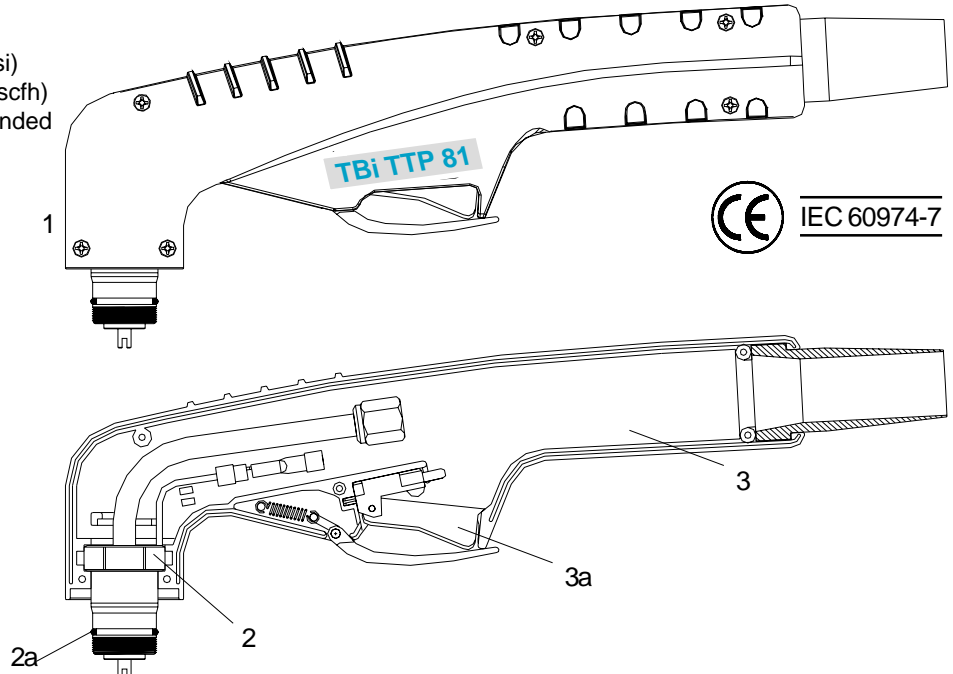

- Higher performances
- Faster Speed
- Cleaner cut

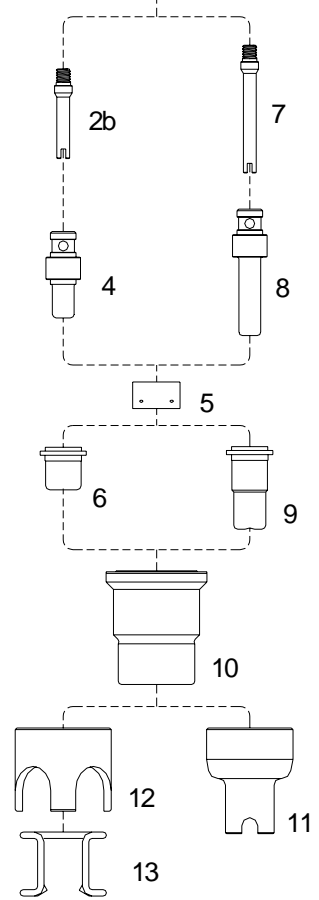

TBi Industries GmbH is in no way affiliated with TRAFIMET®. The parts advertised for sale are not genuine TRAFIMET® parts, but are parts made for and by TBi Industries GmbH. Reference to TRAFIMET® machine, torches and numbers are for your convenience only. We reserve the right to substitute genuine TRAFIMET® parts in place of TBi Industries GmbH parts.

Replacement torch and parts suitable for: TRAFIMET® A80 - Ergo A81

<u>Pos.</u>	<u>Part Number</u>	<u>Ref.-No.</u>	<u>Description</u>	<u>Prod.-Gr.</u>	<u>PU</u>	<u>List price</u>
	447P081306		Torches cpl. with rubber cover Hand Torch TTP 81-6m-G 3/8" RC	30101	1	270,00•
	447P081106		Hand Torch TTP 81-6m-Central Connector-RC	30101	1	316,00•
			Torch head, handle and consumables			
1	447P081001	PF 0140	Torch Head TTP 81 complete with handle	30112	1	120,00•
2	• 447P081002		Torch Head TTP 81	30112	1	101,00•
2a	• 365P156178	EA 0125	O -Ring	30115	20	0,60•
2b	• 441P081050	FH 0560	Diffusor	30110	2	3,20•
3	• 380P200002		Handgrip with switch	30115•	1	16,00•
3a	• 385P021016	BX 0020	Switch	10175	10	3,00•
4	• 441P080005	PR 0109	Electrode - maximum life	30110	10	3,20•
5	• 441P002250	PE 0107	Swirl ring	30110	2	18,40•
6	441P002201	PD 0105-10	Tip 1.0	30110	10	2,30•
	441P002251	PD 0105-11	Tip 1.1	30110	10	2,30•
	• 441P080006	PD 0105-12	Tip 1.2	30110	10	2,30•
7	441P081051	FH 0561	Extended diffusor	30110	2	5,80•
8	441P080007	PR 0115	Extended electrode - maximum life	30110	10	4,30•
9	441P002252	PD 0106-10	Extended tip 1.0	30110	10	2,80•
	441P002253	PD 0106-12	Extended tip 1.2	30110	10	3,10•
10	• 441P001210	PC 0115	Nozzle retaining cap	30109	10	13,90•
11	441P080008	CV 0201	Spacer for contact cutting	30109	10	12,60•
12	441P002202	CV 0033	Crown spacer	30110	10	1 0,50•
13	• 441P002203	CV 0028	Spacer spring	30110	10	1,80•
			Accessories			
	441P101890		Circle cutting attachment	30118	1	105,00•
	441P101880		Cutting guide	30118	1	46,00•

• = standard equipment

Suitable for: TRAFIMET® A90 - Ergocut 101

Max Current : 100 Amps
 Duty Cycle: 100 Amps - 60%
 Gas: Air
 Gas Pressure: 4.5-5.0 bar (70 psi)
 Gas Flow: 180 ltr.p.m. (380 scfh)
 Post Flow Time: 90 sec. recommended
 Pilot : Electrode to Tip
 Ignition: HF

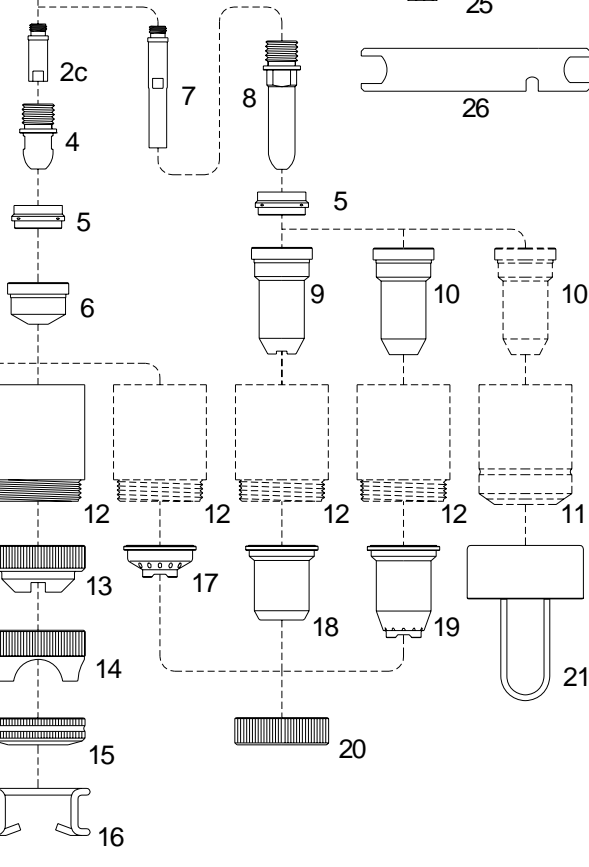
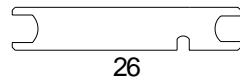
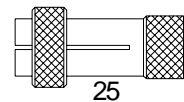
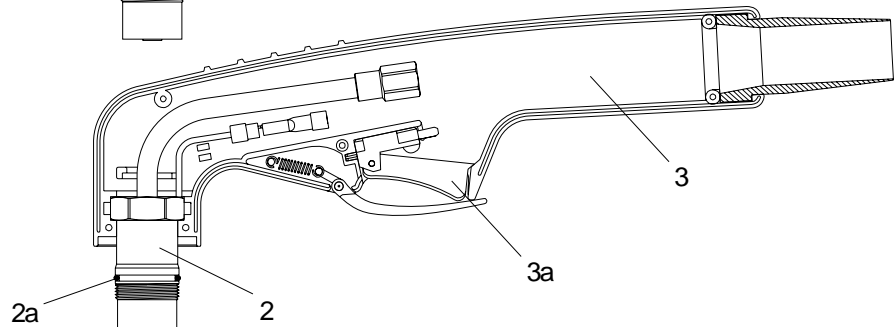
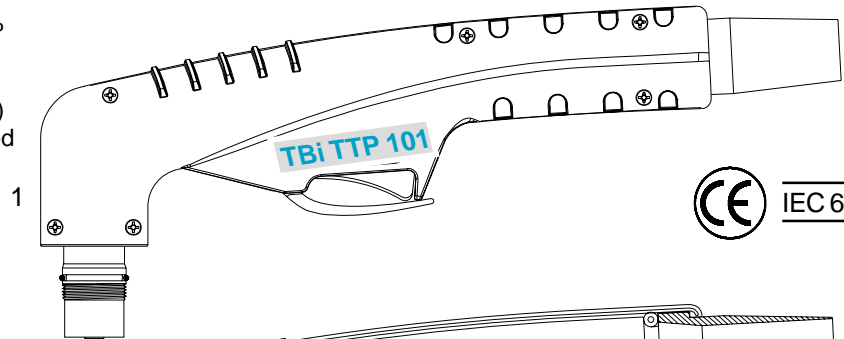

- Higher performances
- Faster Speed
- Cleaner cut

TBi Industries GmbH is in no way affiliated with TRAFIMET®. The parts advertised for sale are not genuine TRAFIMET® parts, but are parts made for and by TBi Industries GmbH. Reference to TRAFIMET® machine, torches and numbers are for your convenience only. We reserve the right to substitute genuine TRAFIMET® parts in place of TBi Industries GmbH parts.

Replacement parts suitable for: TRAFIMET® A90 - Ergocut 101

Pos.	Part Number	Ref.-No.	Description	Prod.-Gr.	PU	List price
			Torches cpl. with rubber cover			
	447P101506		Hand Torch TTP 101-6m-M14x1-RC	30101	1	316,00•
	447P101106		Hand Torch TTP 101-6m-Central Connector-RC	30101	1	363,00•
	447P101512		Hand Torch TTP 101-12m-M14x1-RC	30101	1	405,00•
	447P101112		Hand Torch TTP 101-12m-Central Connector-RC	30101	1	452,00•
			Torch head, handle and consumables			
1	447P101001	PF 0145	Torch Head TTP 101 complete with handle	30112	1	152,00•
2	• 447P101002		Torch Head TTP 101	30112	1	134,00•
2a	• 365P190180	EA 0131	O -Ring	30115	20	0,80•
2b	• 441P090003		Front insulator	30110	1	45,00•
2c	• 441P020300		Diffusor	30110	2	3,20•
3	• 380P200002		Handgrip with microswitch	30115	1	16,00•
3a	• 385P021016	BX 0020	Switch	10175	10	3,00•
4	• 441P010001	PR 0101	Electrode	30110	10	2,60•
5	• 441P020010	PE 0101	Swirl ring	30110	2	12,20•
6	441P020001	PD 0101-11	Tip ø 1.1	30110	10	2,40•
	441P020002	PD 0101-14	Tip ø 1.4	30110	10	2,40•
	• 441P020003	PD 0101-17	Tip ø 1.7	30110	10	2,40•
7	441P020019		Extended Diffusor	30110	10	11,30•
8	441P010020		Extended electrode	30110	10	6,30•
9	441P020015		Extended tip (max. 50AMP)	30110	10	7,30•
10	441P020016		Extended tip ø 1.4 - (for Pos: 19, 20 + 21)	30110	10	6,20•
	441P020017		Extended tip ø 1.7 - (for Pos: 19, 20 + 21)	30110	10	6,20•
11	• 441P010301	PC 0109/0111	Nozzle retaining cap, long life	30109	6	28,90•
12	441P010302	PC 0113/0130	Contact nozzle retaining cap	30109	6	50,40•
	441P010304	PC 0113/0130	Contact nozzle retaining cap, Max.life	30109	10	67,40•
13	441P020011	CV 0023	Spacer for contact cutting	30110	10	12,90•
14	441P102053	CV 0039	Large spacer for contact cutting	30110	10	14,80•
15	446P102063		Spring holder protection nut	30110	10	8,70•
16	446P102064		Spacer spring for code 446P102063	30110	10	2,00•
17	446P102060		Spacer for contact cutting, hand	30109	10	10,90•
18	446P102065	CV 0008	Shield cup, hand (max. 50A) (for Pos. 21 only)	30110	10	10,60•
19	446P102066	CV 0009	Spacer for contact cutting, hand (for Pos. 21 only)	30110	10	15,90•
20	446P102067		Locking nut	30110	10	4,90•
21	446P102044		Spacer complete with springs	30110	10	14,70•
21a	446P102045		Spare springs (20 pcs.)	30110	10	0,90•
22	• 441P020009	CV 0011	Spacer spring	30110	10	1,90•
23	441P010005	CV 0012	Double pointed spacer	30110	10	12,90•
24	441P020301	CV 0014	Crown spacer	30110	6	13,10•
25	441P010303	GR	Extractor for swirl ring	30115	10	12,30•
26	441P020310		Wrench for electrode	30115	10	3,10•
			Accessories			
N/S	446P101990		Circle cutting attachment	30118	1	112,00•
N/S	446P101900		Cutting guide	30118	1	47,00•

• = standard equipment

Suitable for: TRAFIMET® A140 - Ergocut 141

Max Current : 150 Amps
 Duty Cycle: 150 Amps - 60%
 Gas: Air
 Gas Pressure: 4.5-5.0 bar (70 psi)
 Gas Flow: 220 ltr.p.m. (470 scfh)
 Post Flow Time: 90 sec. recommended
 Pilot : Electrode to Tip
 Ignition: HF

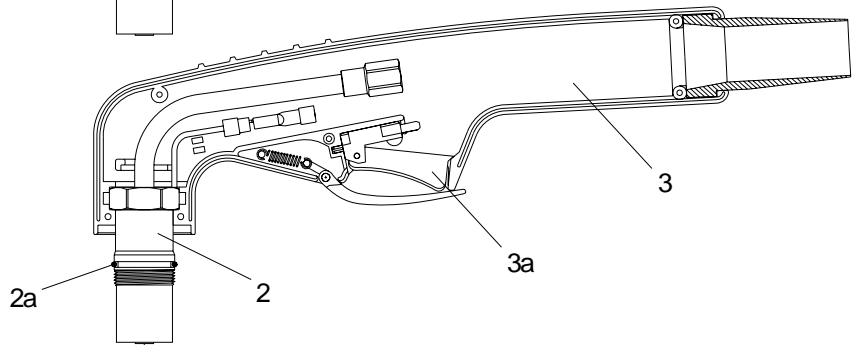
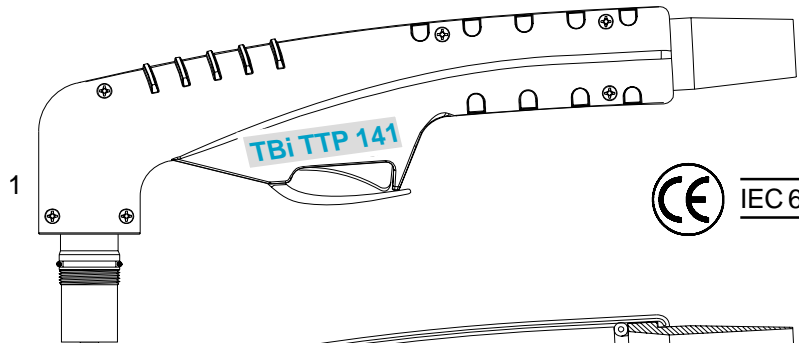

- Higher performances
- Faster Speed
- Cleaner cut

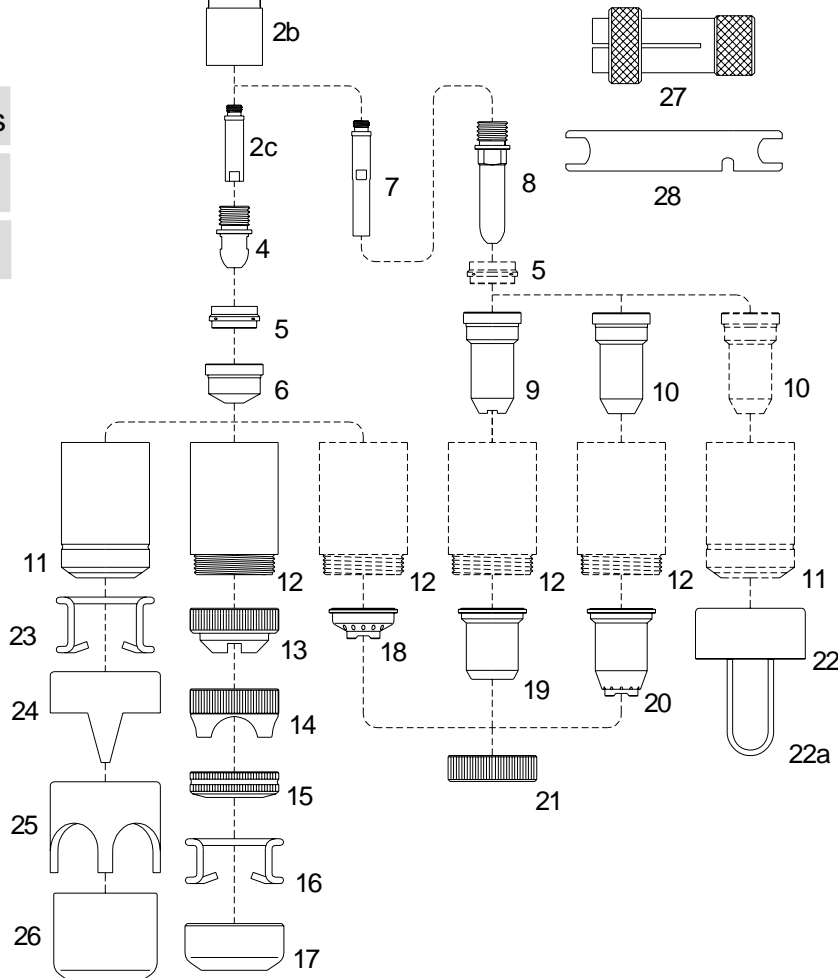

TBi Industries GmbH is in no way affiliated with TRAFIMET®. The parts advertised for sale are not genuine TRAFIMET® parts, but are parts made for and by TBi Industries GmbH. Reference to TRAFIMET® machine, torches and numbers are for your convenience only. We reserve the right to substitute genuine TRAFIMET® parts in place of TBi Industries GmbH parts.

Replacement parts suitable for: TRAFIMET® A140 - Ergocut 141

Pos.	Part Number	Ref.-No.	Description	Prod.-Gr.	PU	List price
			Torches cpl. with rubber cover			
	447P141506		Hand Torch TTP 141-6m-M14x1-RC	30101	1	319,00•
	447P141106		Hand Torch TTP 141-6m-Central Connector-RC	30101	1	366,00•
	447P141512		Hand Torch TTP 141-12m-M14x1-RC	30101	1	408,00•
	447P141112		Hand Torch TTP 141-12m-Central Connector-RC	30101	1	455,00•
			Torch head, handle and consumables			
1	447P141001	PF 0155	Torch Head TTP 141 complete with handle	30112	1	156,00•
2	• 447P141002		Torch Head TTP 141	30112	1	138,00•
2a	• 365P190180	EA 0131	O -Ring	30115	20	0,80•
2b	• 446P102003		Front insulator	30110	2	46,90•
2c	• 446P102002		Diffusor	30110	2	3,20•
3	• 380P200002		Handgrip with microswitch	30115	1	16,00•
3a	• 385P021016	BX 0020	Switch	10175	10	3,00•
4	• 441P010001	PR 0101	Electrode	30110	10	2,60•
5	• 441P020010	PE 0101	Swirl ring	30110	2	12,20•
6	441P020001	PD 0101-11	Tip ø 1.1	30110	10	2,40•
	441P020002	PD 0101-14	Tip ø 1.4	30110	10	2,40•
	441P020003	PD 0101-17	Tip ø 1.7	30110	10	2,40•
	• 441P020004	PD 0101-19	Tip ø 1.9	30110	10	2,40•
	441P020005	PD 0101-30	Gauging tip ø 3.0	30110	10	2,70•
7	446P102004		Extended Diffusor	30110	2	11,30•
8	441P010020		Extended electrode	30110	10	6,30•
9	441P020015		Extended tip (max. 50AMP)	30110	10	7,30•
10	441P020016		Extended tip ø 1.4 - (for Pos: 20, 21 + 22)	30110	10	6,20•
	441P020017		Extended tip ø 1.7 - (for Pos: 20, 21 + 22)	30110	10	6,20•
	441P020018		Extended tip ø 1.9 - (for Pos: 20, 21 + 22)	30110	10	6,20•
11	• 441P010401	PC 0101/0102	Nozzle retaining cap, long life	30109	6	31,60•
12	441P010402	PC 0103/0131	Contact nozzle retaining cap	30109	6	52,80•
	441P010403	PC 0103/0131	Contact nozzle retaining cap, maximum life	30109	6	70,00•
13	441P020011	CV 0023	Spacer for contact cutting	30110	10	12,90•
14	441P102053	CV 0039	Large spacer for contact cutting	30110	10	14,80•
15	446P102063		Spring holder protection nut	30110	10	8,70•
16	446P102064		Spacer spring for code 446P102063	30110	10	2,00•
17	446P102068		Gauging spacer	30109	10	10,10•
18	446P102060		Spacer for contact cutting, hand	30109	10	10,90•
19	446P102065	CV 0008	Shield cup, hand (max. 50A) (for Pos. 21 only)	30110	10	10,60•
20	446P102066	CV 0009	Spacer for contact cutting, hand (for Pos. 21 only)	30110	10	15,90•
21	446P102067		Locking nut	30110	10	4,90•
22	446P102044		Spacer complete with springs	30110	10	14,70•
22a	446P102045		Spare springs (20 pcs)	30110	10	0,90•
23	• 441P020009	CV 0011	Spacer spring	30110	10	1,90•
24	441P010005	CV 0012	Double pointed spacer	30110	10	12,90•
25	441P020301	CV 0014	Crown spacer	30110	6	13,10•
26	446P102051	CV 0013	Gauging spacer	30109	6	9,90•
27	441P010303	GR 60	Extractor for swirl ring	30115	10	12,30•
28	441P020310		Wrench for electrode	30115	10	3,10•
			Accessories			
N/S	446P101990		Circle cutting attachment	30118	1	112,00•
N/S	446P101900		Cutting guide	30118	1	47,00•

• = standard equipment

Suitable for: TRAFIMET® R145 - Ergocut A 151

Max Current : 150 Amps
 Duty Cycle: 150 Amps - 60%
 Gas: Air
 Gas Pressure: 4.5-5.0 bar (70 psi)
 Gas Flow: 220 ltr.p.m. (470 scfh)
 Post Flow Time: 90 sec. recommended
 Pilot : Electrode to Tip
 Ignition: HF

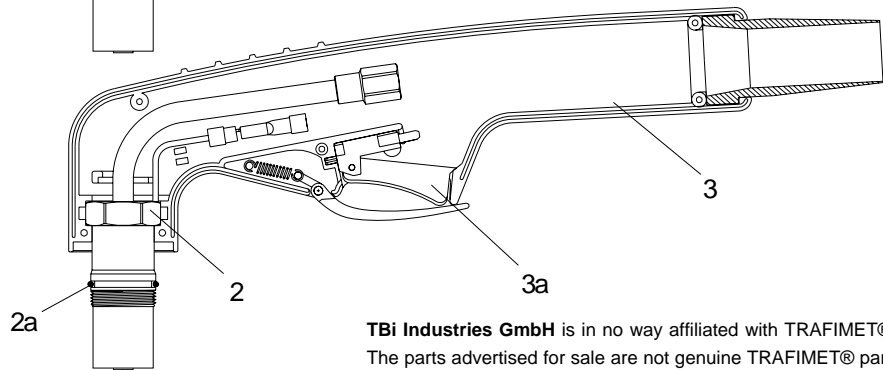
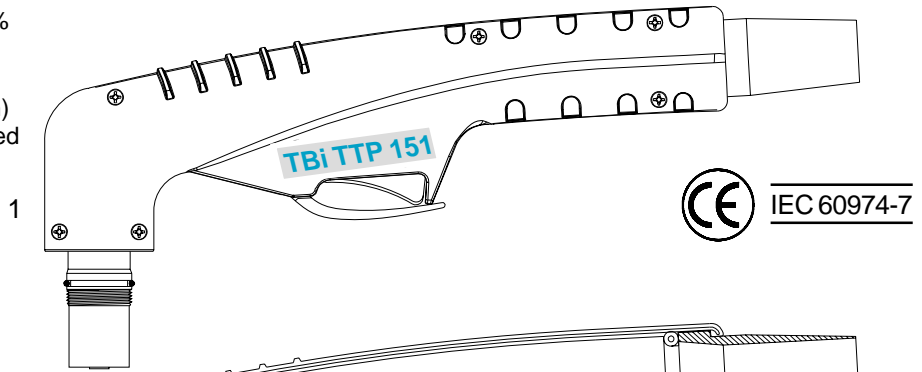

TBi Industries GmbH is in no way affiliated with TRAFIMET®. The parts advertised for sale are not genuine TRAFIMET® parts, but are parts made for and by **TBi Industries GmbH**. Reference to TRAFIMET® machine, torches and numbers are for your convenience only. We reserve the right to substitute genuine TRAFIMET® parts in place of **TBi Industries GmbH** parts.

- Higher performances
- Faster Speed
- Cleaner cut

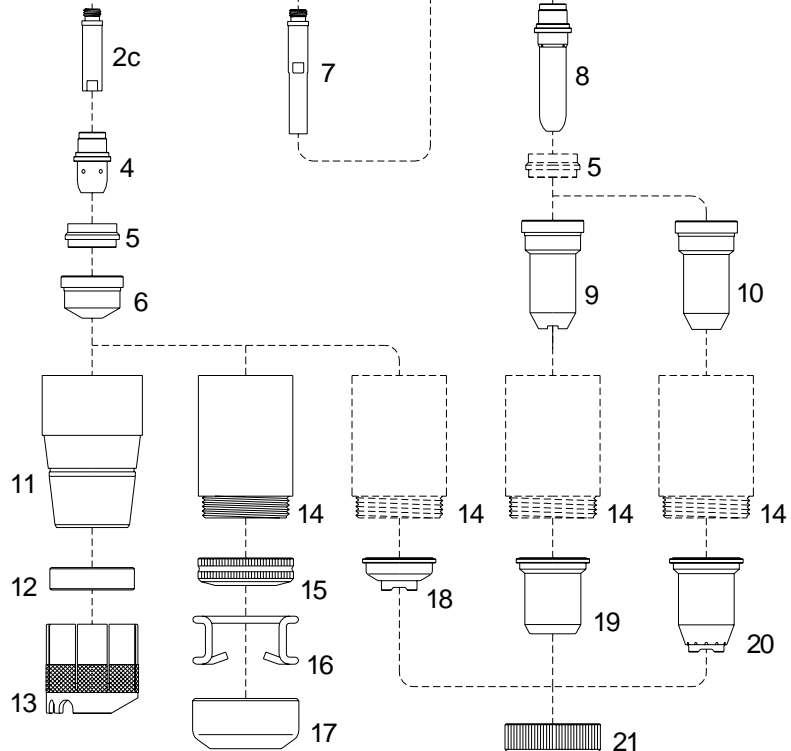

TBi Industries GmbH is in no way affiliated with TRAFIMET®. The parts advertised for sale are not genuine TRAFIMET® parts, but are parts made for and by **TBi Industries GmbH**. Reference to TRAFIMET® machine, torches and numbers are for your convenience only. We reserve the right to substitute genuine TRAFIMET® parts in place of **TBi Industries GmbH** parts.

Replacement parts suitable for: R145 - Ergocut A151

<u>Pos.</u>	<u>Part Number</u>	<u>Ref.-No.</u>	<u>Description</u>	<u>Prod.-Gr.</u>	<u>PU</u>	<u>List price</u>
			Torches cpl. with rubber cover			
	447P151506		Hand Torch TTP 151-6m-M14x1-RC	30101	1	363,00•
	447P151106		Hand Torch TTP 151-6m-Central Connector-RC	30101	1	410,00•
	447P151512		Hand Torch TTP 151-12m-M14x1-RC	30101	1	487,00•
	447P151112		Hand Torch TTP 151-12m-Central Connector-RC	30101	1	534,00•
			Torch head, handle and consumables			
1	447P151001	PF 0160	Torch Head TTP 151 complete with handle	30112	1	160,00•
2	• 447P151002		Torch Head TTP 151	30112	1	142,00•
2a	• 365P190180	EA 0131	O -Ring	30115	20	0,80•
2b	• 446P102003		Front insulator	30110	2	46,90•
2c	• 446P102002		Diffusor	30110	2	3,20•
3	• 380P200002		Handgrip with switch	30115	1	16,00•
3a	• 385P021016	BX 0020	Switch	10175	10	3,00•
4	• 441P145001	PR 0111	Electrode	30110	10	4,80•
5	• 441P145002	PE 0103	Insulating spacer	30110	2	14,90•
6	441P145003	PD 0109-14	Tip ø 1.4	30110	10	2,80•
	441P145004	PD 0109-16	Tip ø 1.6	30110	10	2,80•
	• 441P145005	PD 0109-18	Tip ø 1.8	30110	10	2,80•
	441P145006	PD 0109-30	Gouging tip ø 3.0	30110	10	2,80•
7	446P102004		Extended Diffusor	30110	2	11,30•
8	441P145010	PR 0116	Extended electrode	30110	10	7,10•
9	441P145014	PD 0111	Extended tip ø 1.2 (max 50A)	30110	10	7,30•
10	441P145011	PD 0117-14	Extended tip ø 1.4 - (for use with Pos. 20+21)	30110	10	6,90•
	441P145012	PD 0117-17	Extended tip ø 1.7 - (for use with Pos. 20+21)	30110	10	6,90•
	441P145013	PD 0117-19	Extended tip ø 1.9 - (for use with Pos. 20+21)	30110	10	6,90•
11	• 441P145007	PC 0120	Nozzle retaining cap	30109	6	39,20•
12	• 441P145008	BW 0139	Nozzle shield	30109	10	4,60•
13	• 441P145009	CV 1105	Cage spacer	30109	10	17,90•
14	441P010402	PC 0103/0131	Contact nozzle retaining cap	30109	6	52,80•
	441P010403	PC 0103/0131	Contact nozzle retaining cap, Max.life	30109	6	70,00•
15	446P102063		Spring holder protection nut	30110	10	8,70•
16	446P102064		Spacer spring for code 446P102063	30110	10	2,00•
17	446P102068		Gauging spacer	30109	10	10,10•
18	446P102060		Spacer for contact cutting, hand	30109	10	10,90•
19	446P102065	CV 0008	Shield cup, hand (tip max. 50A) (use with Pos. 21)	30110	10	10,60•
20	446P102066	CV 0009	Spacer for contact cutting, hand (use with Pos. 21)	30110	10	15,90•
21	446P102067		Locking nut	30110	10	4,90•
			Accessories			
N/S	446P101990		Circle cutting attachment	30118	1	112,00•
N/S	446P101900		Cutting guide	30118	1	47,00•

• = standard equipment

Technical Data:

Max Current :	250 Amps
Duty Cycle:	250 Amps - 100%
Coolant flow:	1.90 ltr.p.m. (0.5 gpm)
Coolant Pressure:	3.5 bar (50 psi)
Gas:	Air/N ₂
Gas Pressure:	4.8-5.0 bar (70-80 psi)
Gas Flow:	120 ltr.p.m. (250 scfh)
Pilot :	Electrode to Tip
Ignition:	HF

*Water Cooled
250A at 100%*

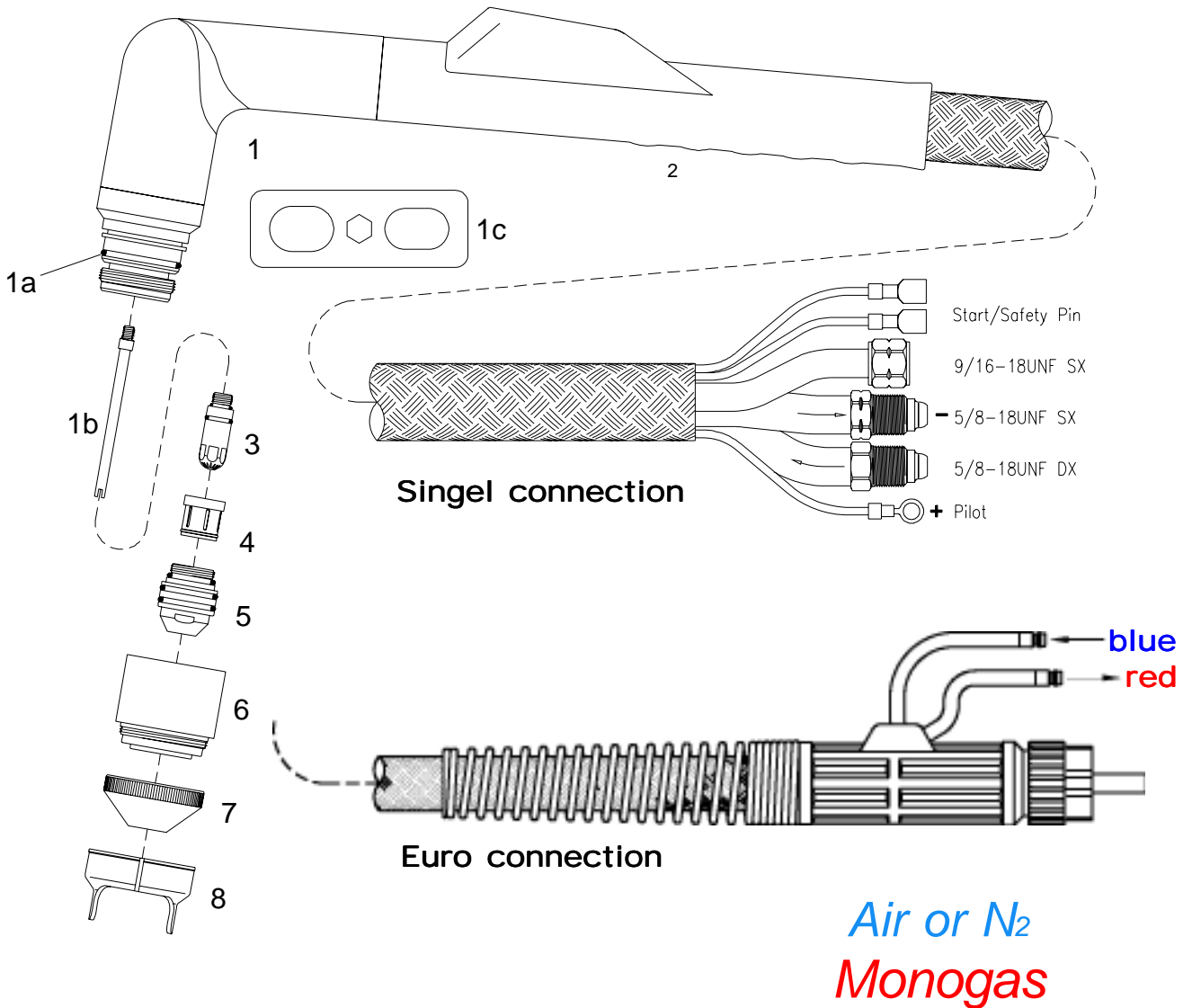

Torches and replacement parts:

<u>Pos.</u>	<u>Part Number</u>	<u>Ref.-No.</u>	<u>Description</u>	<u>Prod.-Gr.</u>	<u>PU</u>	<u>List price</u>
			Torches cpl. with rubber cover			
	448P001Z07		Hand torch PLC 250W-7.50m, Euro Connector	30102	1	1.525,00 •
	448P001Z15		Hand torch PLC 250W-15.00m, Euro Connector	30102	1	1.875,00 •
	448P100107		Cable assembly for PLC 250W-7.50m, Euro Connector	30115	1	720,00 •
	448P100115		Cable assembly for PLC 250W-15.00m, Euro Connector	30115	1	1.060,00 •
	448P001E07		Hand torch PLC 250W-7.50m, single connection	30102	1	1.355,00 •
	448P001E15		Hand torch PLC 250W-15.00m, single connection	30102	1	1.705,00 •
	448P100207		Cable assembly for PLC 250W-7.5m, single connection	30115	1	570,00 •
	448P100215		Cable assembly for PLC 250W-15.00, single connection	30115	1	900,00 •
			Torch head, handle and consumables			
1	• 448P101001		Hand torch head PLC 250W-85°	30113	1	645,00 •
1a	• 365P000002		O-Ring	30115	20	0,70 •
1b	• 448P102001		Cooling Tube	30115	2	19,00 •
1c	• 391P102047		Wrench for Tip and Electrode	30115	1	9,60 •
2	• 380P200385		Hande complete with microswitch for PLC 250W	30115	1	24,00 •
3	• 448P101002		Electrode, Air/N2 50-250A	30111	5	10,70 •
4	• 448P102002		Gas Distributor 50-250A	30111	2	35,00 •
	448P102003		Gas Distributor 50-225A	30111	2	145,00 •
5	448P101010		Plasma tip, 50A	30111	5	9,95 •
	448P101011		Plasma tip, 100A	30111	5	9,95 •
	448P101012		Plasma tip, 150A	30111	5	9,95 •
	448P101013		Plasma tip, 200A	30111	5	9,95 •
	• 448P101014		Plasma tip, 250A	30111	5	9,95 •
6	• 448P101020		Shield Cup Body	30111	1	141,00 •
7	448P102005		End Cup, 50A	30111	1	16,90 •
	448P102006		End Cup, 100-200A	30111	1	16,90 •
	• 448P102007		End Cup, 250A	30111	1	16,90 •
8	• 448P102008		Double pointed Spacer	30111	1	24,50 •
	•		= standard equipment			

Technical Data:

Max Current :	250 Amps
Duty Cycle:	250 Amps - 100%
Coolant flow:	1.90 ltr.p.m. (0.5 gpm)
Coolant Pressure:	3.5 bar (50 psi)
Gas:	Air/N ₂
Gas Pressure:	4.8-5.0 bar (70-80 psi)
Gas Flow:	120 ltr.p.m. (250 scfh)
Pilot :	Electrode to Tip
Ignition:	HF

Water Cooled
250A at 100%

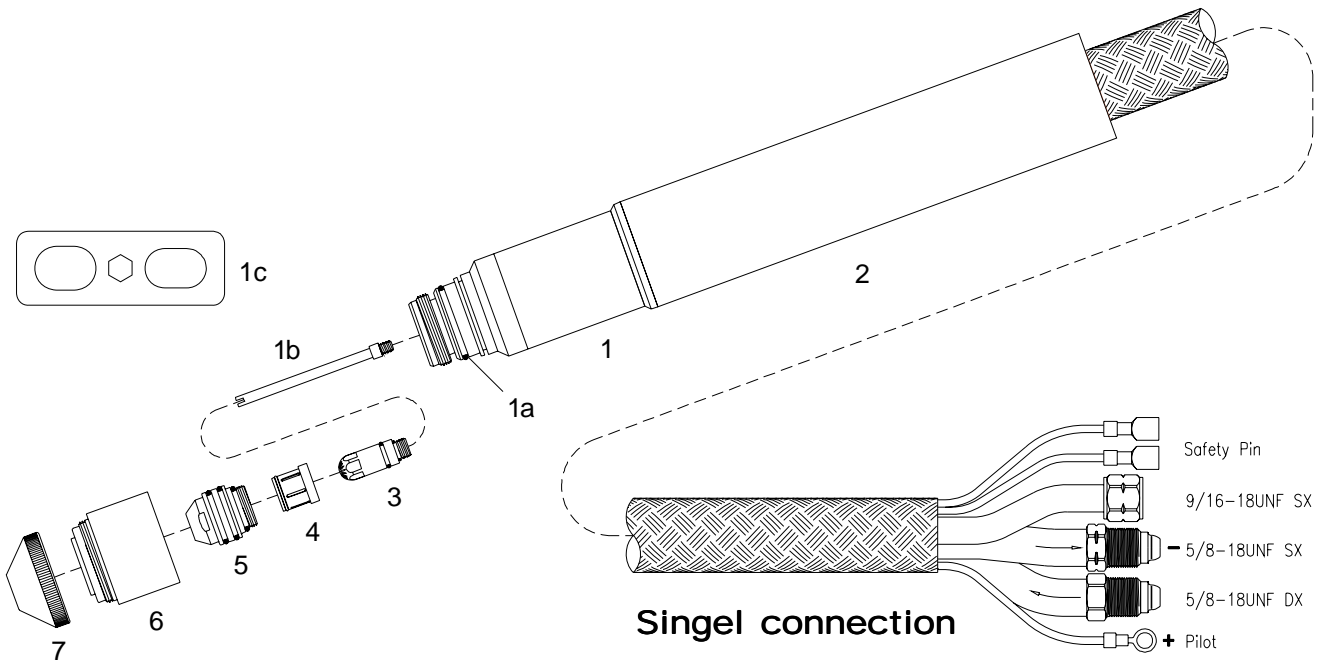

Air or N₂

Monogas

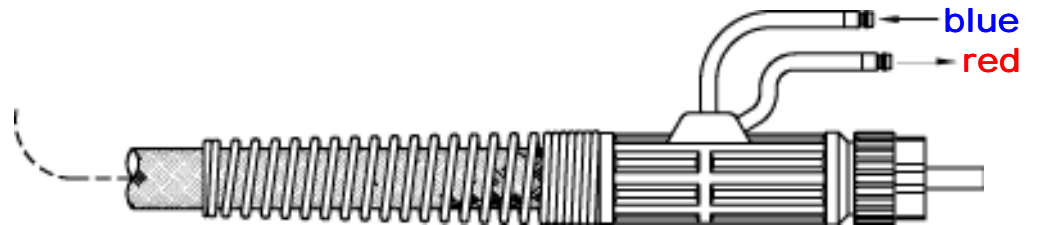

Euro connection

Torches and replacement parts:

<u>Pos.</u>	<u>Part Number</u>	<u>Description</u>	<u>Prod.-Gr.</u>	<u>PU</u>	<u>List price</u>
Torches cpl. with shielded cover (Monogas)					
	448P002E07	Machine torch PLC AUT 250W-7.50m, single connection	30102	1	1.385,00 •
	448P002E15	Machine torch PLC AUT 250W-15.00m, single connection	30102	1	1.750,00 •
	448P100307	Cable assembly for PLC AUT 250W-7.5m, single connection	30115	1	522,00 •
	448P100315	Cable assembly for PLC AUT 250W-15.00, single connection	30115	1	848,00 •
	448P002Z07	Machine torch PLC AUT 250W-7.50m, Euro Connector	30102	1	1.575,00 •
	448P002Z15	Machine torch PLC AUT 250W-15.00m, Euro Connector	30102	1	1.940,00 •
	448P100407	Cable assembly for PLC AUT 250W-7.50m, Euro Connector	30115	1	659,00 •
	448P100415	Cable assembly for PLC AUT 250W-15.00m, Euro Connector	30115	1	964,00 •
Torches cpl. with shielded cover (Dual Gas)					
	448P003E07	Machine torch PLC AUT 250W-2-7.50m, single connection	30102	1	1.445,00 •
	448P003E15	Machine torch PLC AUT 250W-2-15.00m, single connection	30102	1	1.799,00 •
	448P100507	Cable assembly for PLC AUT 250W-2-7.5m, single connection	30115	1	585,00 •
	448P100515	Cable assembly for PLC AUT 250W-2-15.00, single connection	30115	1	921,00 •
Torch head, handle and consumables					
1	• 448P101025	Machine torch head PLC AUT 250W, straight (Monogas)	30113	1	595,00 •
	448P101026	Machine torch head PLC AUT 250W-2 - straight (Dual Gas)	30113	1	641,00 •
1a	• 365P000002	O-Ring	30115	20	0,70 •
1b	• 448P102001	Cooling Tube	30115	2	19,00 •
1c	• 391P102047	Wrench for Tip and Electrode	30115	1	9,60 •
2	• 380P200386	Handle for PLC AUT 250W	30115	1	118,00 •
3	• 448P101002	Electrode, Air/N2 50-250A	30111	5	10,70 •
	448P101027	Electrode, O2 - 50-250A	30111	5	13,10 •
	448P101028	Electrode, N2 - 50-250A	30111	5	28,90 •
	448P101029	Electrode, Ar/H2 - 50-250A	30111	5	34,90 •
4	• 448P102002	Gas Distributor 50-250A	30111	2	35,00 •
	448P102003	Gas Distributor 50-225A	30111	2	145,00 •
5	448P101010	Plasma tip, 50A	30111	5	9,95 •
	448P101011	Plasma tip, 100A	30111	5	9,95 •
	448P101012	Plasma tip, 150A	30111	5	9,95 •
	448P101013	Plasma tip, 200A	30111	5	9,95 •
	• 448P101014	Plasma tip, 250A	30111	5	9,95 •
6	• 448P101020	Shield Cup Body	30111	1	141,00 •
7	448P102005	End Cup, 50A	30111	1	16,90 •
	448P102006	End Cup, 100-200A	30111	1	16,90 •
	• 448P102007	End Cup, 250A	30111	1	16,90 •

• = standard equipment

**** Electrodes only for use with dual gas torch**

Cable connection for PLC AUT 250W and 250W-2

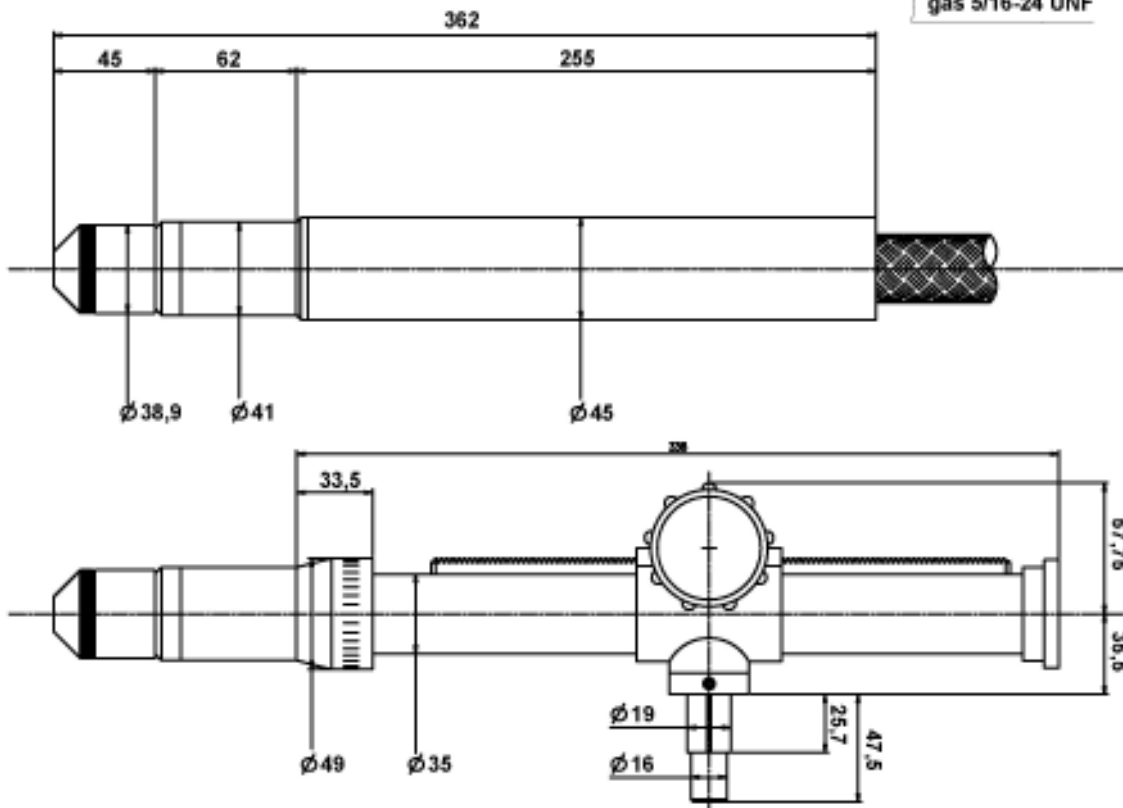
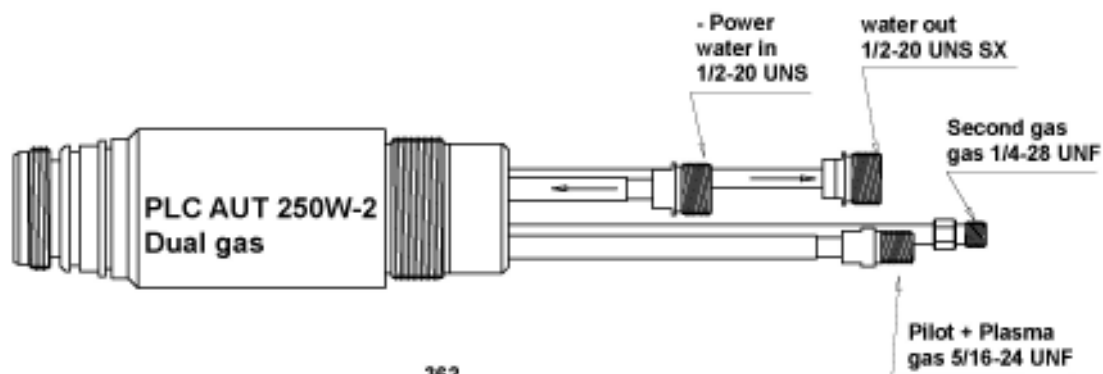
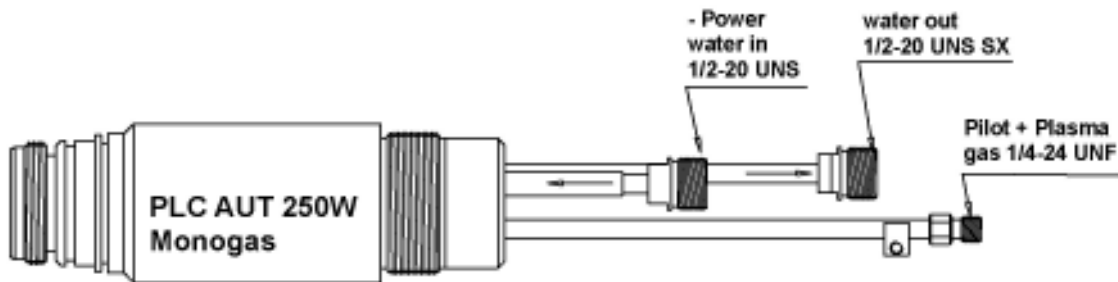

TBi PLC 250W Gas flow comparison chart

Material	Preflow	Pisana	Second gas	AMP	Preflow ltr.p.m.	Plasmagas ltr.p.m.	Second gas ltr.p.m.	
Stainless Steel		Air	Air	50		37	108	
				100		39	66	
				150		39	66	
				200		39	66	
				250		39	66	
			ArH2	N2	150		39	85
					200		39	85
					250		39	85
			N2	H2O	100		39	8
					150		39	3 - 9
					200		39	7 - 9
					250		39	7 - 9
	Mild Steel		Air	Air	50		30	40
					100		39	66
					150		39	66
				200		39	66	
				250		39	66	
		N2	O2	Air	50	20	28	45
					100	29	39	66
					150	29	39	66
					200	29	39	66
					250	29	39	66
Aluminium			Air	Air	50		30	90
					100		39	59
					150		39	59
					200		39	59
					250		39	59
			ArH2	N2	150		38	61
					200		38	61
					250		38	61
			N2	H2O	100		39	8
					150		39	9
					200		39	9
					250		39	9

Technical Data:

Max Current : 30-120 Amps
 Duty Cycle: 120 Amps - 60%
 Gas: Air
 Gas Pressure: 4.6-5.0 bar (70-80 psi)
 Gas Flow: 200 ltr.p.m. (420 scfh)
 Post Flow Time: 90 sec. recommended
 Pilot : Electrode to Tip
 Ignition: Without HF

RPT Torch for HYPERTHERM® Plasma Systems
PowerMax® 1000/1250/1650

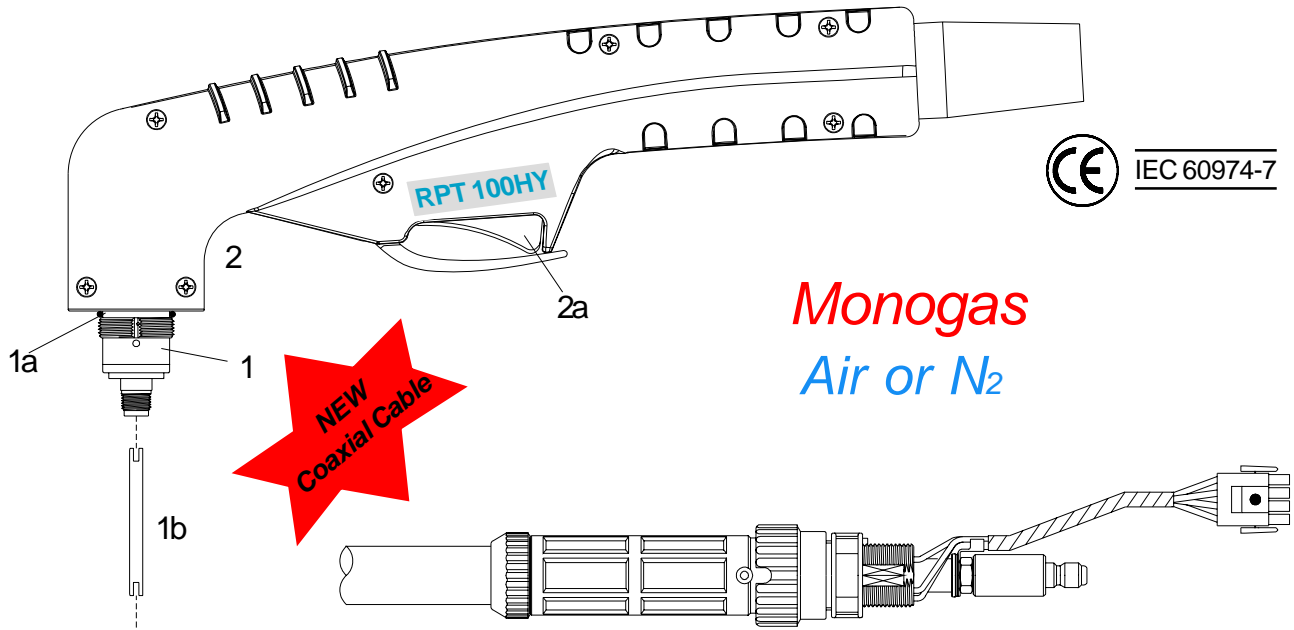

Direct connection

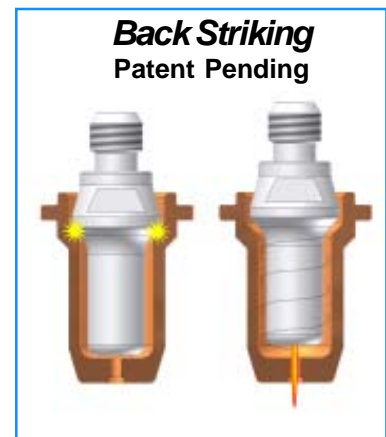
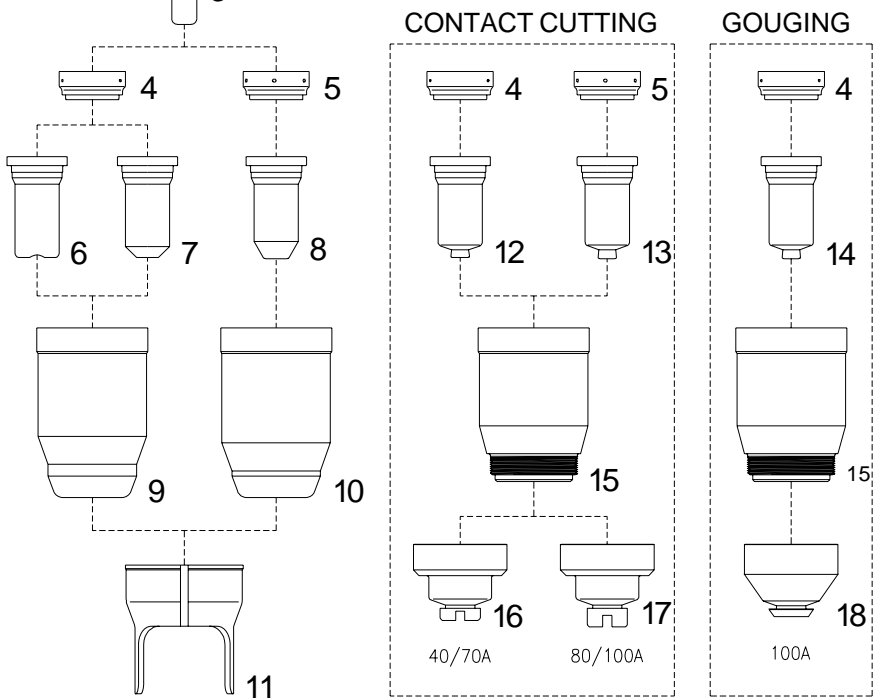

Torches and consumable parts for RPT 100HY

<u>Pos.</u>	<u>Part Number</u>	<u>Description</u>	<u>Prod.-Gr.</u>	<u>PU</u>	<u>List price</u>
		Torches cpl. with rubber cover			
	447P100C07	Hand cutting torch TBI RPT 100HY-7.50m Direct connection	30101	1	539,00 •
	447P100C15	Hand cutting torch TBI RPT 100HY-15.0m Direct connection	30101	1	665,00 •
	447P100907	Cable assembly for TBI RPT 100HY-7.50m Direct connection	30115	1	302,00 •
	447P100915	Cable assembly for TBI RPT 100HY-15.0m Direct connection	30115	1	438,00 •
		Torch head, handle and consumables			
1	• 447P101020	Torch body, TBI 100 RPT 70°	30112	1	137,50 •
1a	• 365P000001	O-Ring TBI 100 RPT	30115	20	0,50 •
1b	• 447P102002	Cooling tube TBI 100 RPT	30115	2	6,50 •
2	• 380P200399	Handle black, 2 poles, TBI 100 RPT	30115	1	17,10 •
2a	385P021016	Trigger, red, 2 poles	10175	10	3,00 •
3	• 447P101010	Electrode, Back Striking TBI 100 RPT	30110	10	2,60 •
4	447P102001	Swirl ring (30/70A) TBI 100 RPT	30110	2	10,90 •
5	• 447P102003	Swirl ring (80/100A) TBI 100 RPT	30110	2	11,60 •
6	447P102005	Tip, cutting,0.9mm (30-40A) TBI 100 RPT, Back Striking	30110	10	3,30 •
7	447P102006	Tip, cutting,1.0mm (40-50A) TBI 100 RPT, Back Striking	30110	10	3,20 •
	447P102007	Tip, cutting,1.1mm (50-60A) TBI 100 RPT, Back Striking	30110	10	3,20 •
	447P102008	Tip, cutting,1.2mm (60-70A) TBI 100 RPT, Back Striking	30110	10	3,20 •
8	447P102009	Tip, cutting,1.4mm (80-90A) TBI 100 RPT, Back Striking	30110	10	3,30 •
	447P102010	Tip, cutting,1.5mm (100A) TBI 100 RPT, Back Striking	30110	10	3,30 •
9	447P101025	Retaining cap, hand, 30 - 70 A TBI 100 RPT	30109	6	23,90 •
10	447P101026	Retaining cap, hand, 80 - 100 A TBI 100 RPT	30109	6	23,90 •
11	447P102015	Double pointed spacer TBI 100 RPT	30110	10	7,80 •
N/S	441P020310	Wrench for electrode	30115	10	3,10 •
12	447P102030	Contact tip, 1.0mm (40-50A) TBI 100 RPT, Back Striking	30110	10	3,40 •
	447P102031	Contact tip, 1.1mm (50-60A) TBI 100 RPT, Back Striking	30110	10	3,40 •
	447P102032	Contact tip, 1.2mm (60-70A) TBI 100 RPT, Back Striking	30110	10	3,40 •
13	• 447P102033	Contact tip, 1.4mm (80-90A) TBI 100 RPT, Back Striking	30110	10	3,50 •
	447P102034	Contact tip, 1.5mm (100A) TBI 100 RPT, Back Striking	30110	10	3,50 •
14	• 447P102035	Tip, gouging (100A) TBI 100 RPT, Back Striking	30110	10	3,70 •
15	447P101027	Shield cup body TBI 100 RPT	30109	6	27,80 •
16	• 447P102016	Shield cup, hand, 40 - 70 A TBI 100 RPT	30109	6	11,60 •
17	447P102017	Shield cup, hand, 80 - 100 A TBI 100 RPT	30109	6	12,00 •
18	447P102018	Shield cup, gouging, TBI 100 RPT	30109	6	11,20 •
		Accessories			
N/S	447P101900	Circle cutting attachment, TBI 100 RPT	30118	1	99,00 •

- RPT torch standard equipment

Technical Data:

Max Current : 30-120 Amps
 Duty Cycle: 120 Amps - 60%
 Gas: Air
 Gas Pressure: 4.6-5.0 bar (70-80 psi)
 Gas Flow: 200 ltr.p.m. (420 scfh)
 Post Flow Time: 90 sec. recommended
 Pilot : Electrode to Tip
 Ignition: Without HF

RPT Torch for HYPERTHERM® Plasma Systems
PowerMax® 1000/1250/1650

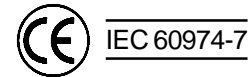

Monogas
 Air or N₂

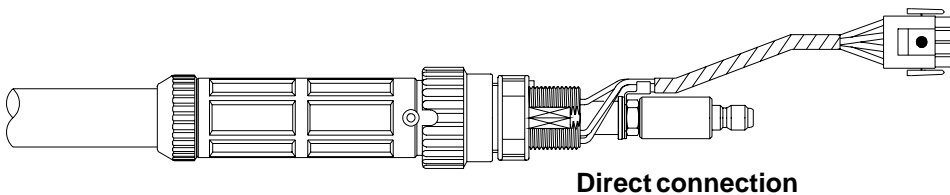
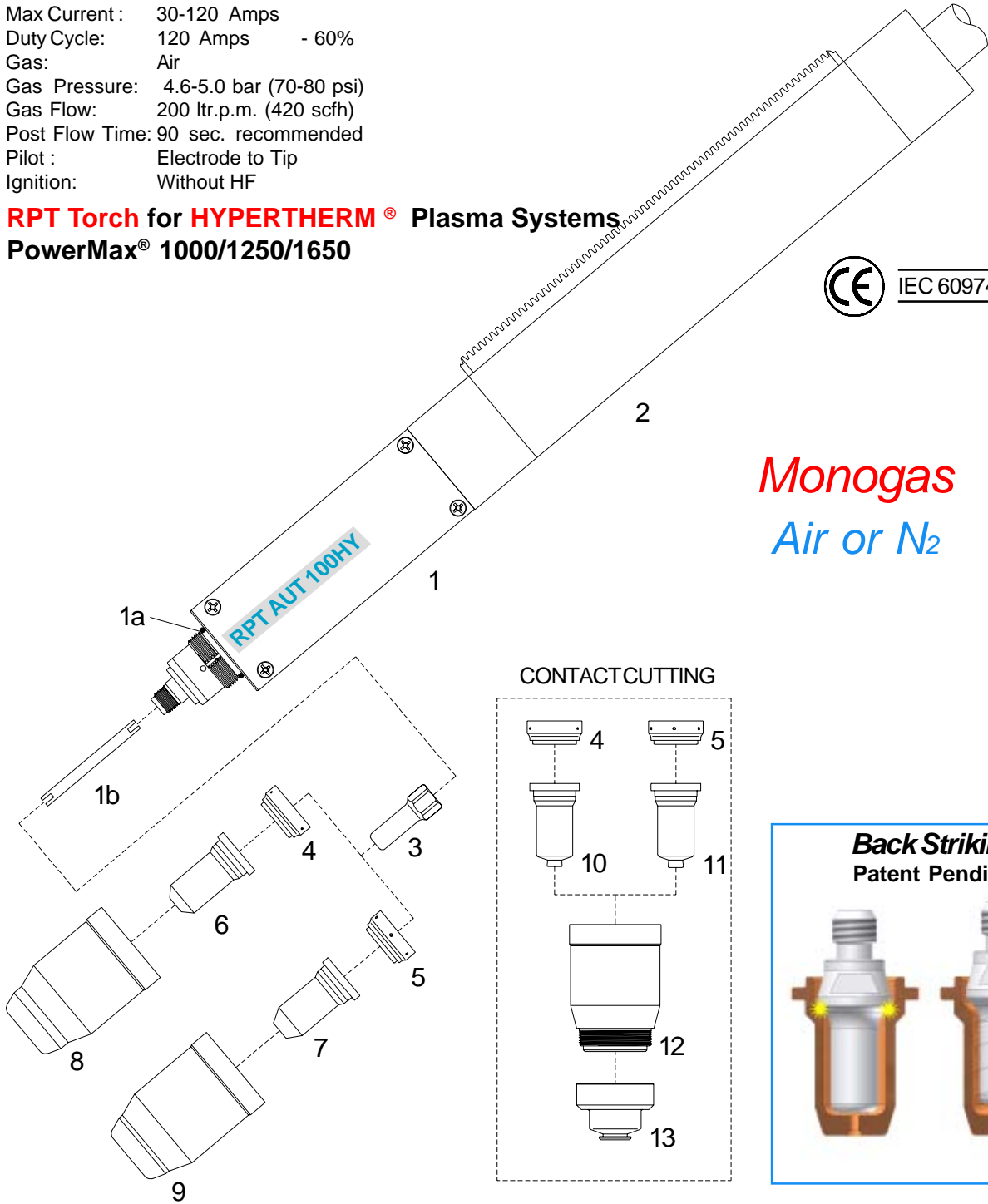

Torches and consumable parts for RPT 100HY

<u>Pos.</u>	<u>Part Number</u>	<u>Description</u>	<u>Prod.-Gr.</u>	<u>PU</u>	<u>List price</u>
		Torches cpl. with rubber cover			
	447P200C07	Machine cutting torch RPT AUT 100HY-7.50m-180°-Direct connection	30101	1	660,00 •
	447P200C15	Machine cutting torch RPT AUT 100HY-15.0m-180°-Direct connection	30101	1	799,00 •
	447P200907	Cable assembly for RPT AUT 100HY-7.50m, direct connection	30115	1	307,00 •
	447P200915	Cable assembly for RPT AUT 100HY-15.00m, direct connection	30115	1	444,00 •
		Torch head, handle and consumables			
1	• 447P101021	Machine torch body, Tbi 100 RPT 180°	30112	1	191,00 •
1a	• 365P000001	O-Ring Tbi 100 RPT	30115	20	0,50 •
1b	• 447P102002	Cooling tube Tbi 100 RPT	30115	2	6,50 •
2	• 380P000904	Fiberglas handle Tbi 100 RPT with rack	30115	1	102,00 •
3	• 447P101010	Electrode, Back Striking Tbi 100 RPT	30110	10	2,60 •
4	447P102001	Swirl ring (30/70A) Tbi 100 RPT	30110	2	10,90 •
5	• 447P102003	Swirl ring (80/100A) Tbi 100 RPT	30110	2	11,60 •
6	447P102006	Tip, cutting,1.0mm (40-50A) Tbi 100 RPT, Back Striking	30110	10	3,20 •
	447P102007	Tip, cutting,1.1mm (50-60A) Tbi 100 RPT, Back Striking	30110	10	3,20 •
	447P102008	Tip, cutting,1.2mm (60-70A) Tbi 100 RPT, Back Striking	30110	10	3,20 •
7	447P102009	Tip, cutting,1.4mm (80-90A) Tbi 100 RPT, Back Striking	30110	10	3,30 •
	447P102010	Tip, cutting,1.5mm (100A) Tbi 100 RPT, Back Striking	30110	10	3,30 •
8	447P101025	Retaining cap, hand, 30 - 70 A Tbi 100 RPT	30109	6	23,90 •
9	• 447P101026	Retaining cap, hand, 80 - 100 A Tbi 100 RPT	30109	6	23,90 •
N/S	• 441P020310	Wrench for electrode	30115	10	3,10 •
10	447P102030	Contact tip, 1.0mm (40-50A) Tbi 100 RPT, Back Striking	30110	10	3,40 •
	447P102031	Contact tip, 1.1mm (50-60A) Tbi 100 RPT, Back Striking	30110	10	3,40 •
	447P102032	Contact tip, 1.2mm (60-70A) Tbi 100 RPT, Back Striking	30110	10	3,40 •
11	• 447P102033	Contact tip, 1.4mm (80-90A) Tbi 100 RPT, Back Striking	30110	10	3,50 •
	447P102034	Contact tip, 1.5mm (100A) Tbi 100 RPT, Back Striking	30110	10	3,50 •
12	447P101027	Shield cup body Tbi 100 RPT	30109	6	27,80 •
13	447P102019	Shield cup, machine, Tbi 100 RPT	30109	6	11,20 •

- RPT torch standard equipment